

# 2003 Chevrolet Suburban C1500

2003 SYSTEM WIRING DIAGRAMS Chevrolet - Suburban

## 2003 SYSTEM WIRING DIAGRAMS

Chevrolet - Suburban

### AIR CONDITIONING

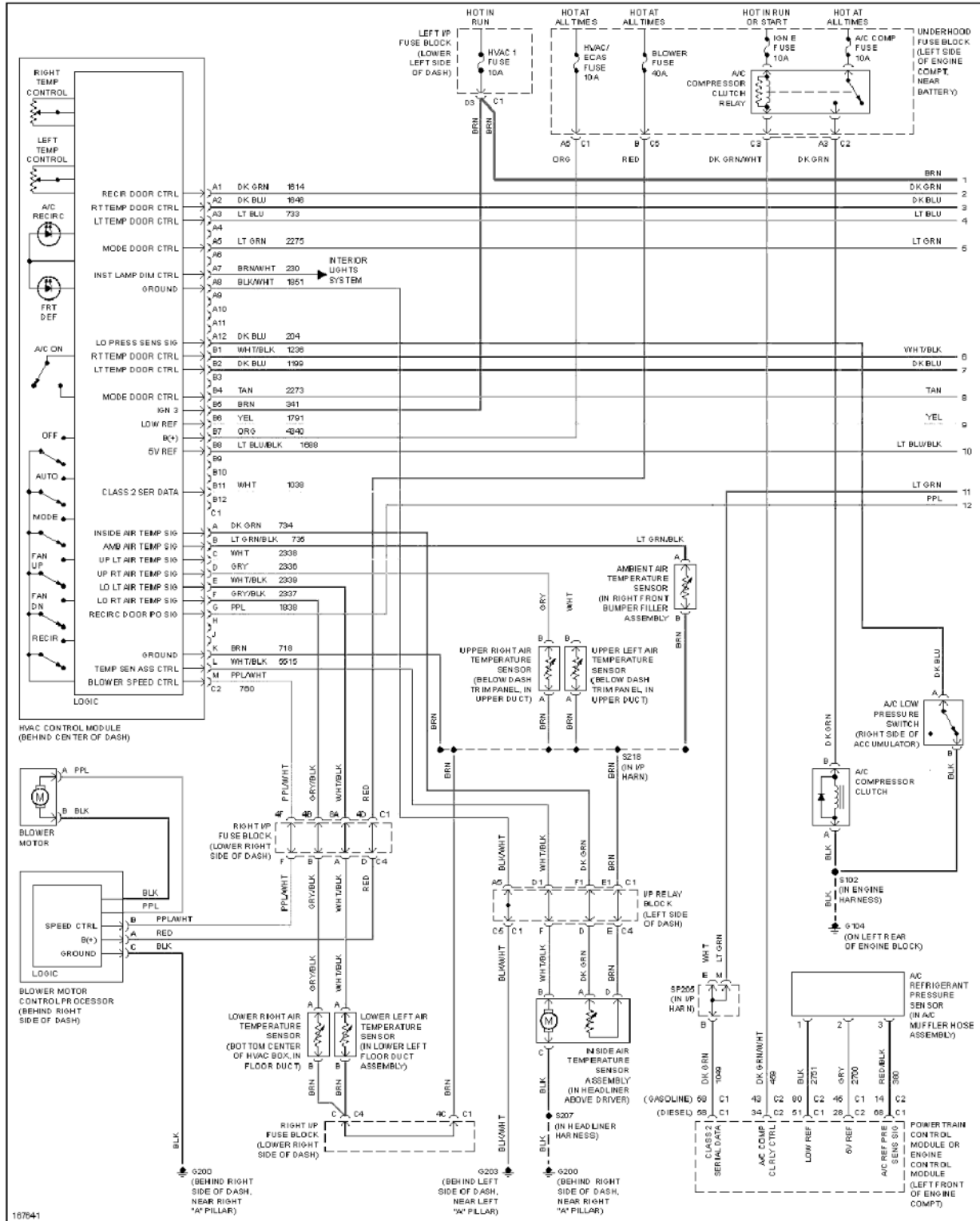
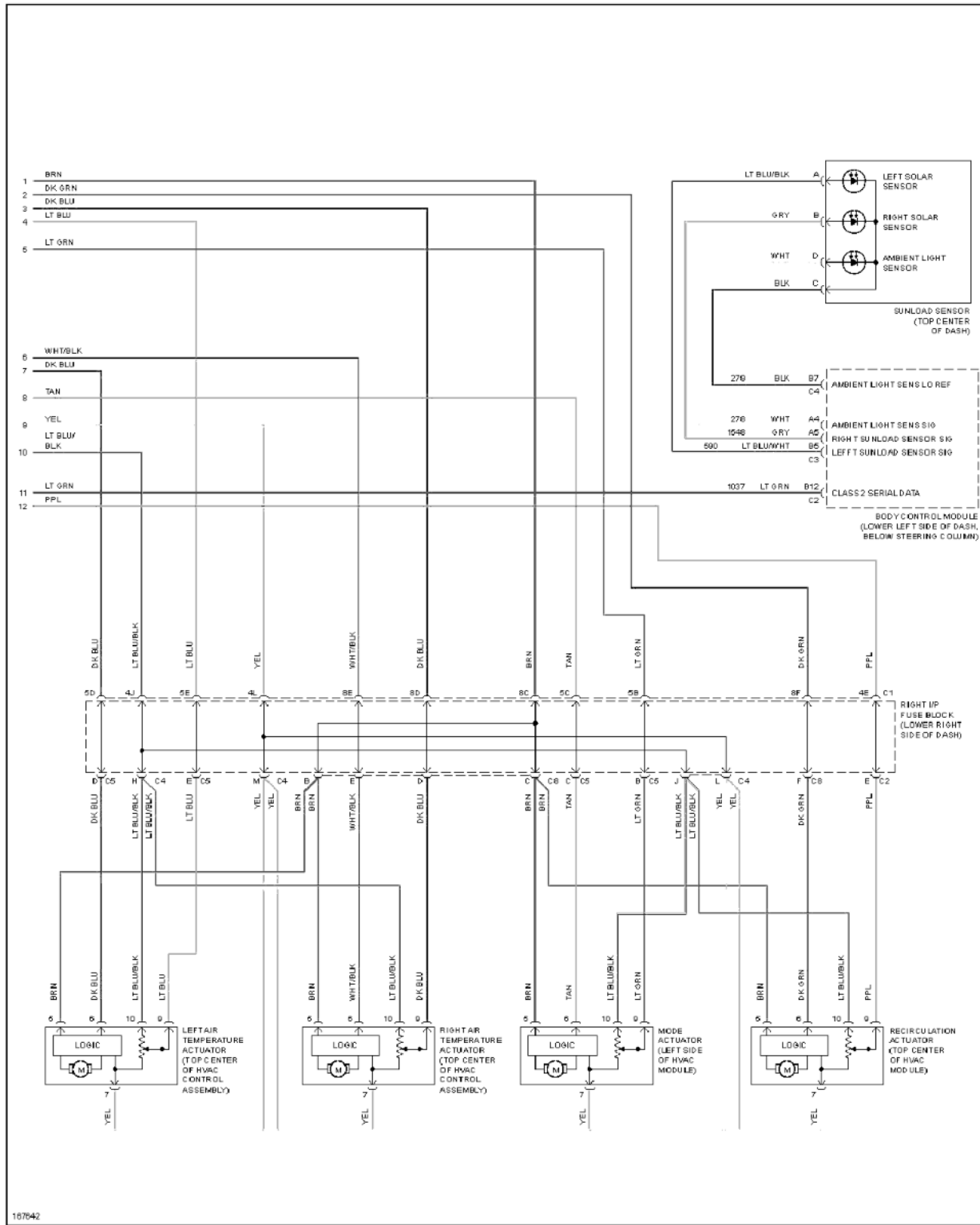

Fig. 1: Automatic A/C Circuit (1 of 2)

# 2003 Chevrolet Suburban C1500

## 2003 SYSTEM WIRING DIAGRAMS Chevrolet - Suburban



**Fig. 2: Automatic A/C Circuit (2 of 2)**

# 2003 Chevrolet Suburban C1500

## 2003 SYSTEM WIRING DIAGRAMS Chevrolet - Suburban

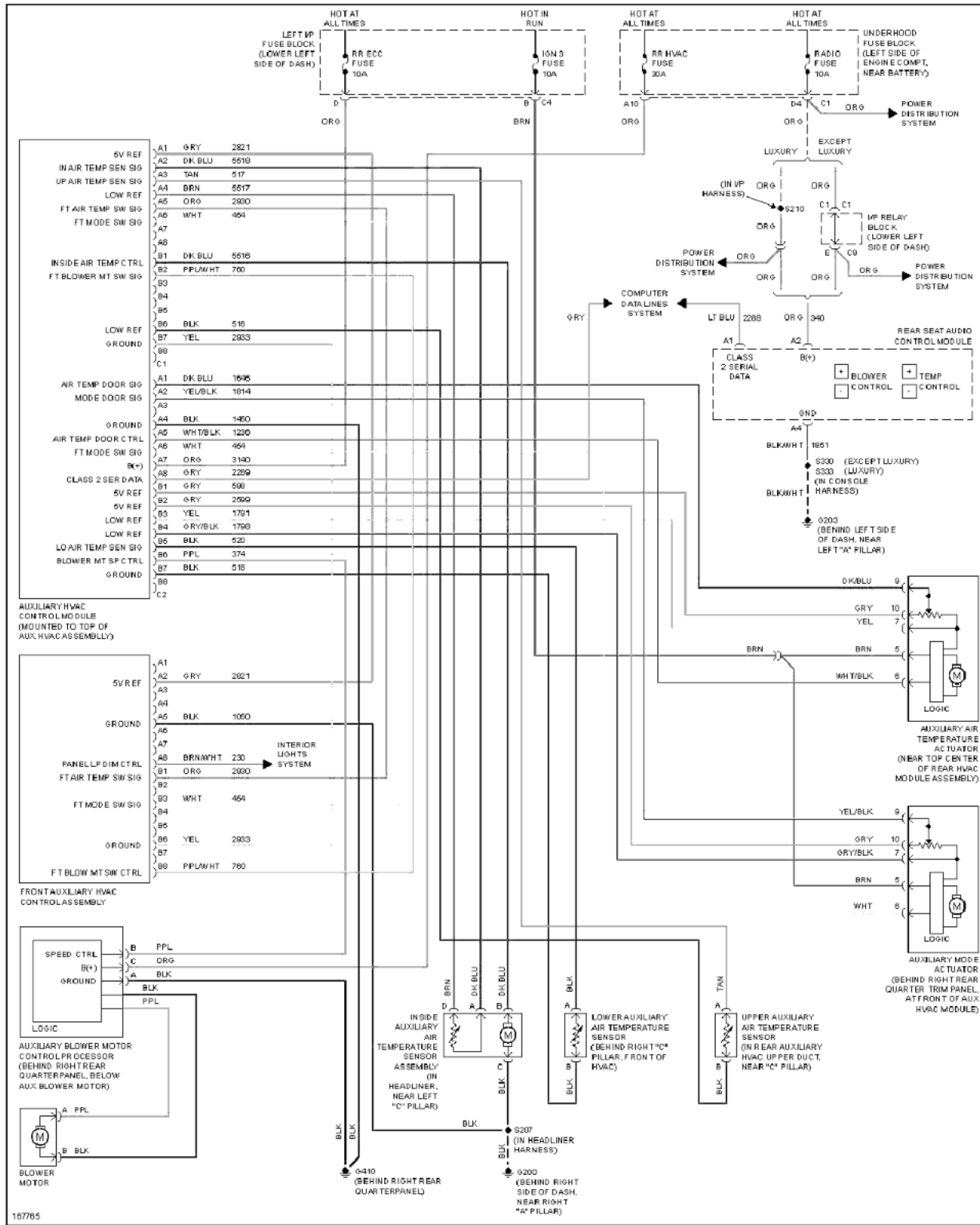

**Fig. 3: Automatic A/C Circuit, Rear A/C**

# 2003 Chevrolet Suburban C1500

2003 SYSTEM WIRING DIAGRAMS Chevrolet - Suburban

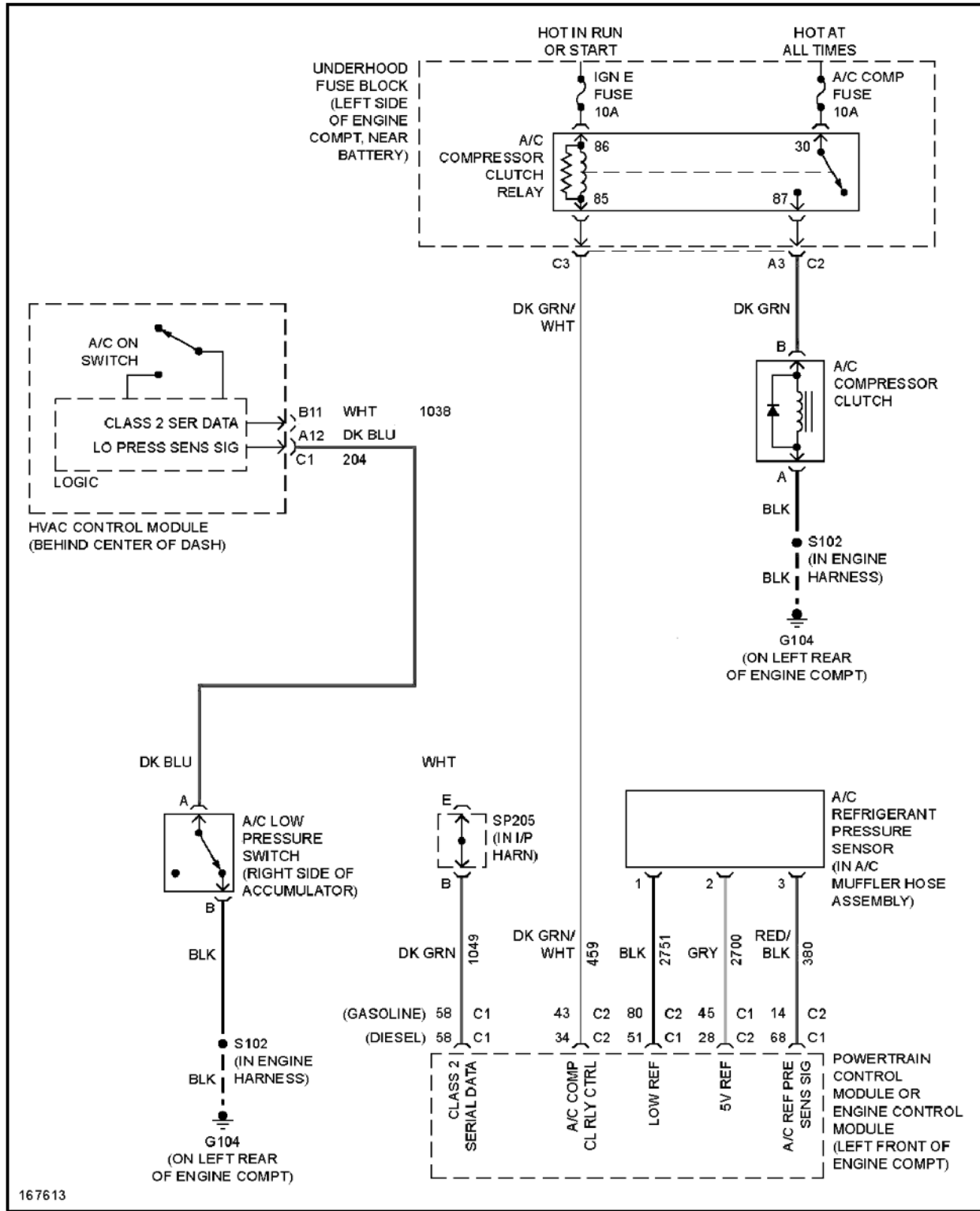

Fig. 4: Compressor Circuit

# 2003 Chevrolet Suburban C1500

## 2003 SYSTEM WIRING DIAGRAMS Chevrolet - Suburban

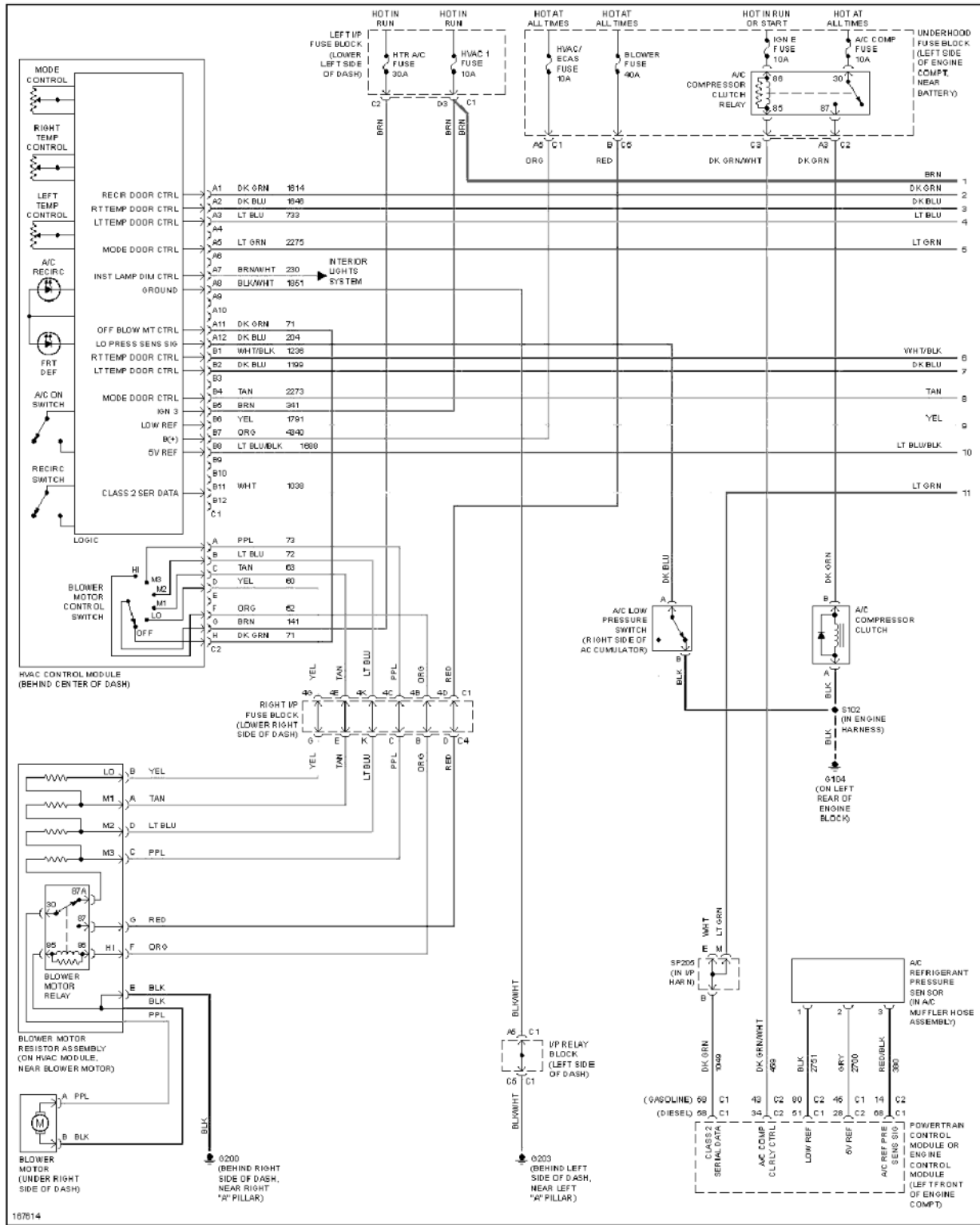

Fig. 5: Manual A/C Circuit (1 of 2)

# 2003 Chevrolet Suburban C1500

## 2003 SYSTEM WIRING DIAGRAMS Chevrolet - Suburban

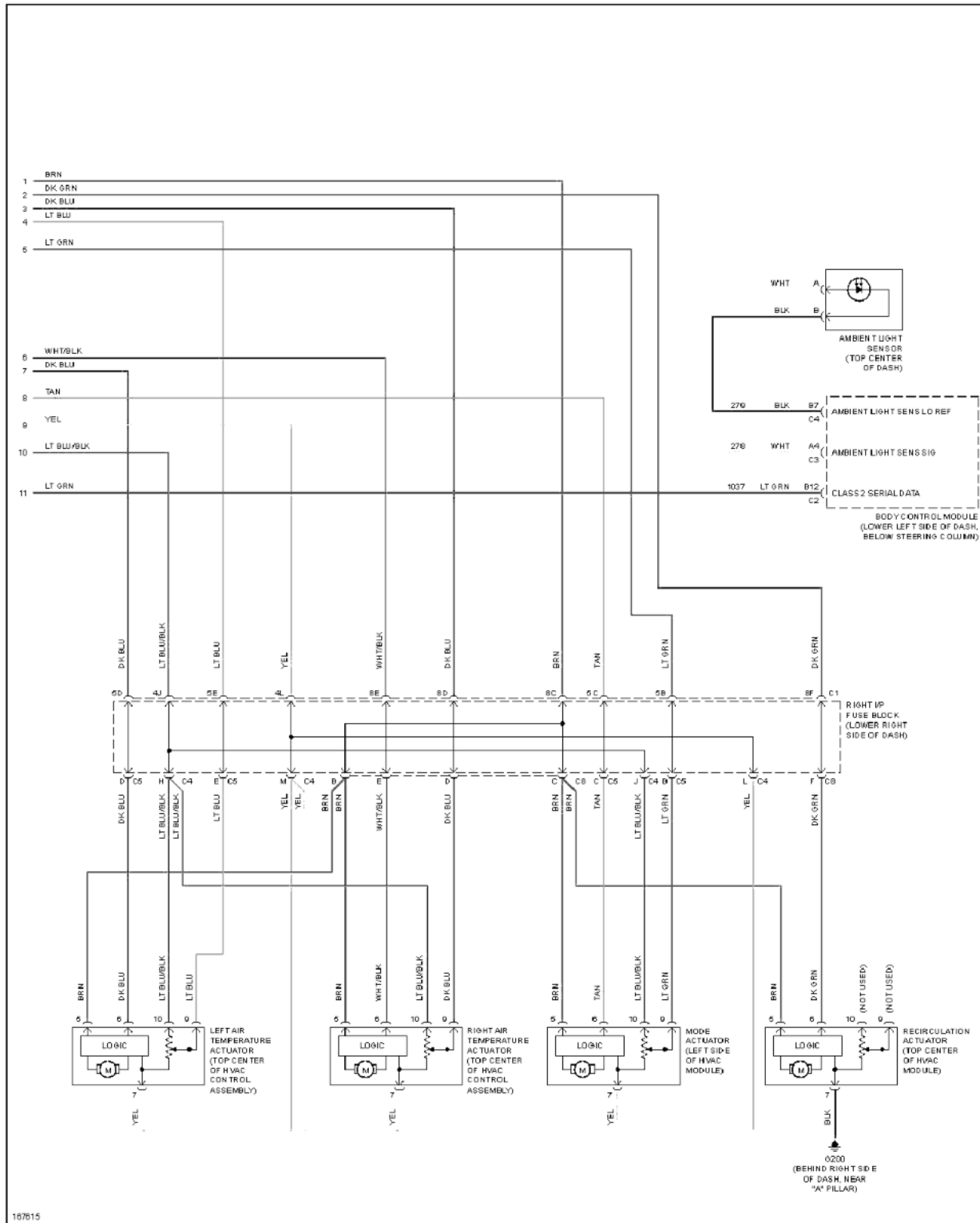
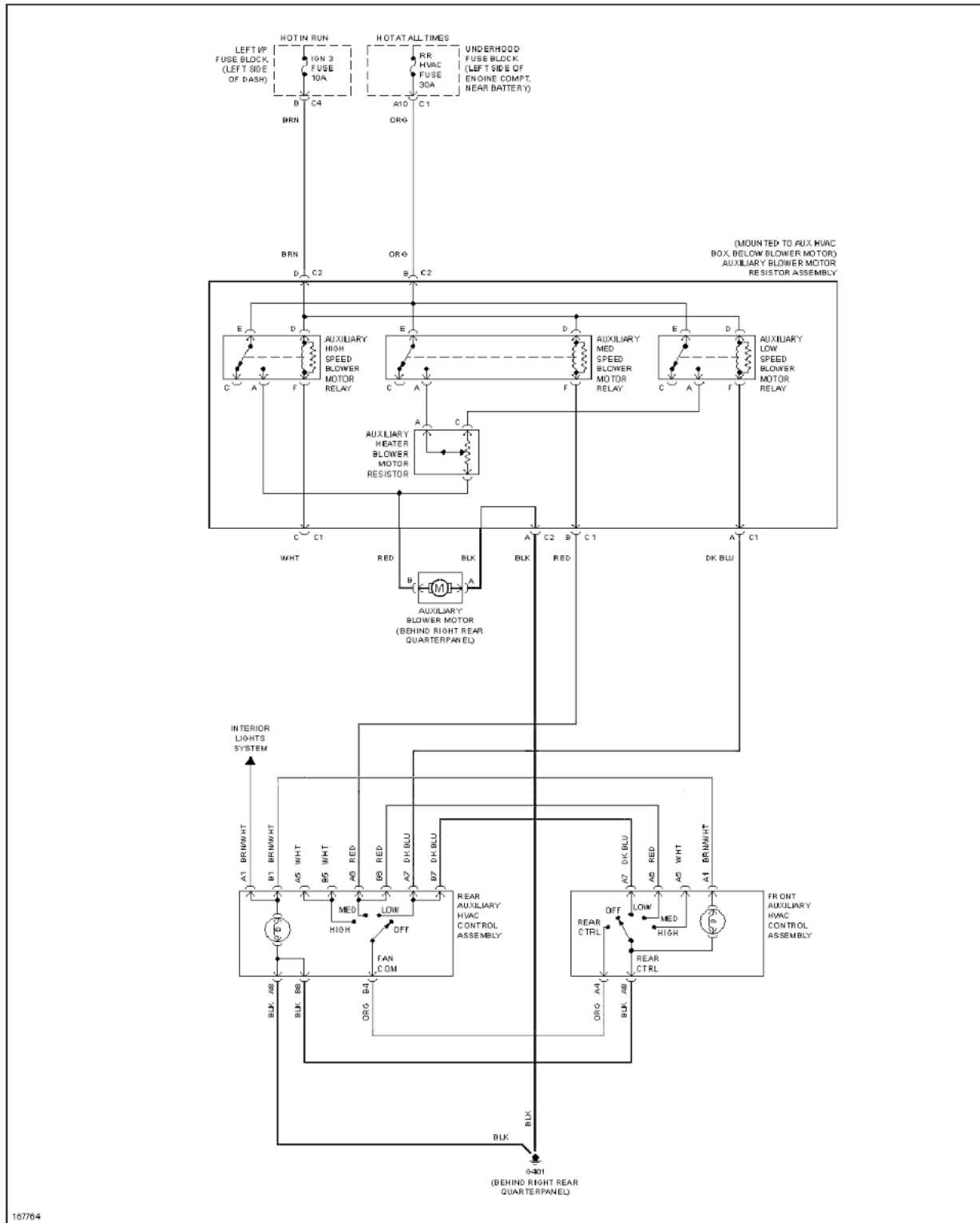

Fig. 6: Manual A/C Circuit (2 of 2)

# 2003 Chevrolet Suburban C1500

## 2003 SYSTEM WIRING DIAGRAMS Chevrolet - Suburban



**Fig. 7: Manual A/C Circuit, Rear W/ A/C only**

# 2003 Chevrolet Suburban C1500

## 2003 SYSTEM WIRING DIAGRAMS Chevrolet - Suburban

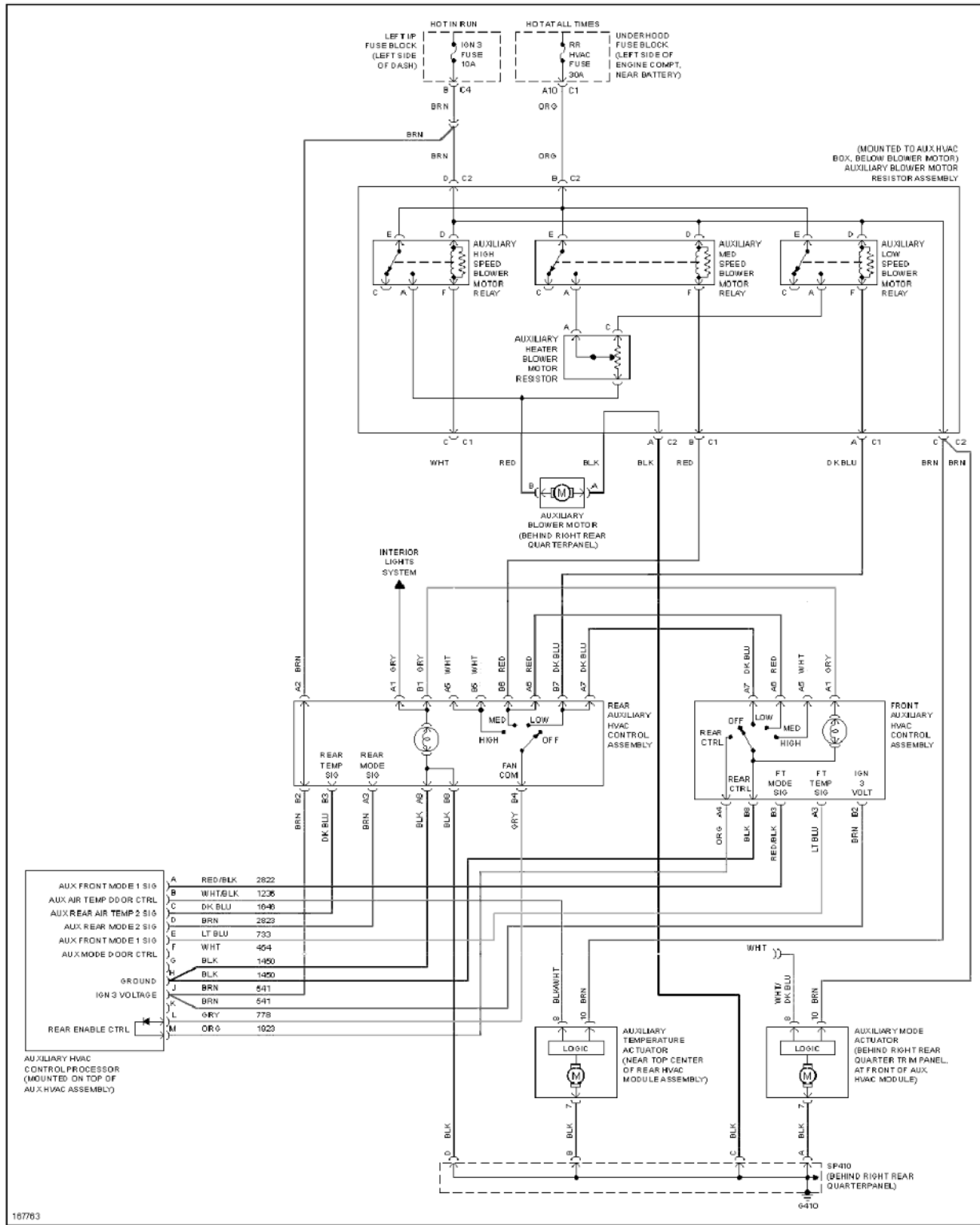
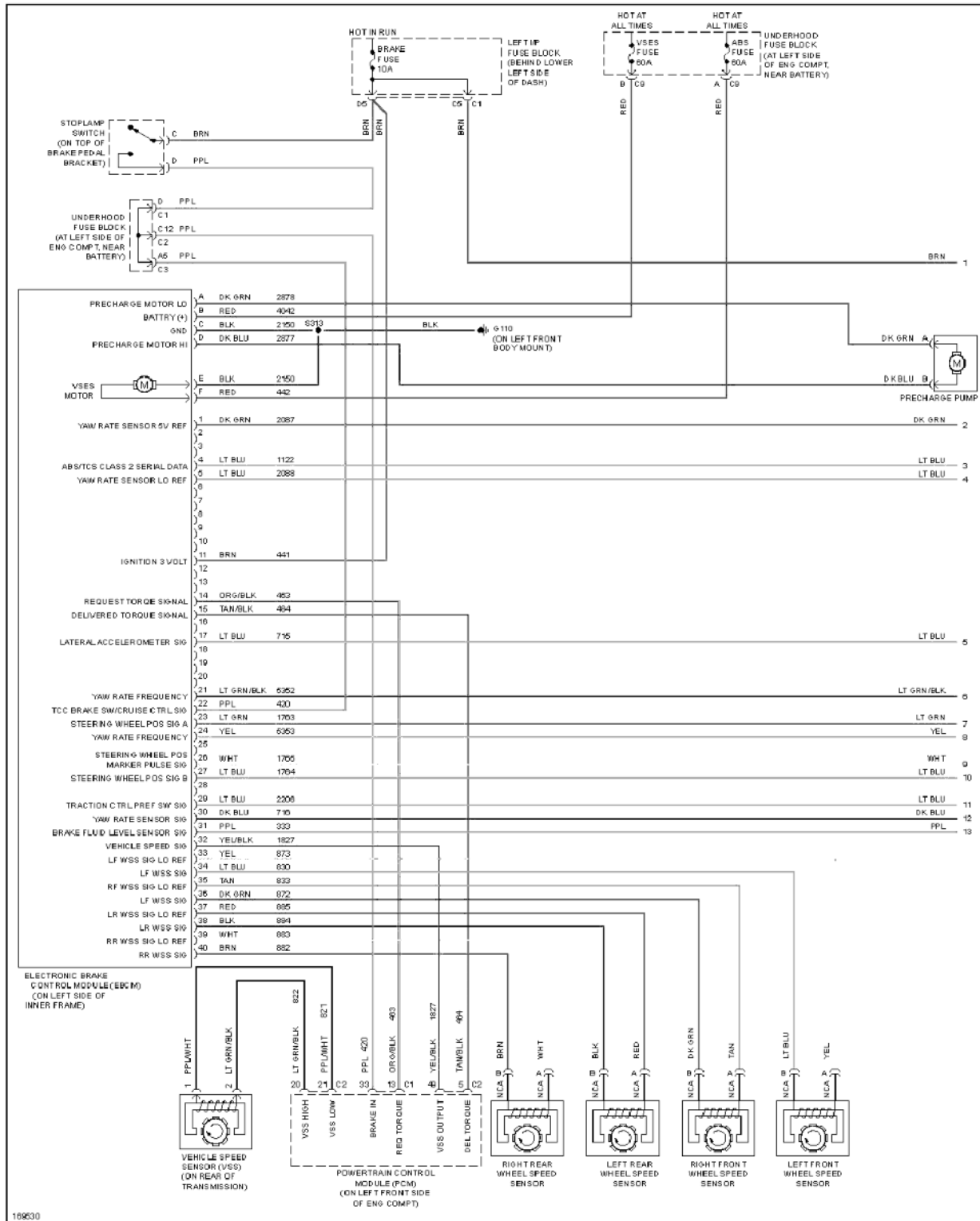

Fig. 8: Manual A/C Circuit, Rear W/ Heat & A/C

## ANTI-LOCK BRAKES

# 2003 Chevrolet Suburban C1500

## 2003 SYSTEM WIRING DIAGRAMS Chevrolet - Suburban



**Fig. 9: Anti-lock Brakes Circuit, W/ Vehicle Speed Enhancement Stability (1 of 2)**

# 2003 Chevrolet Suburban C1500

## 2003 SYSTEM WIRING DIAGRAMS Chevrolet - Suburban

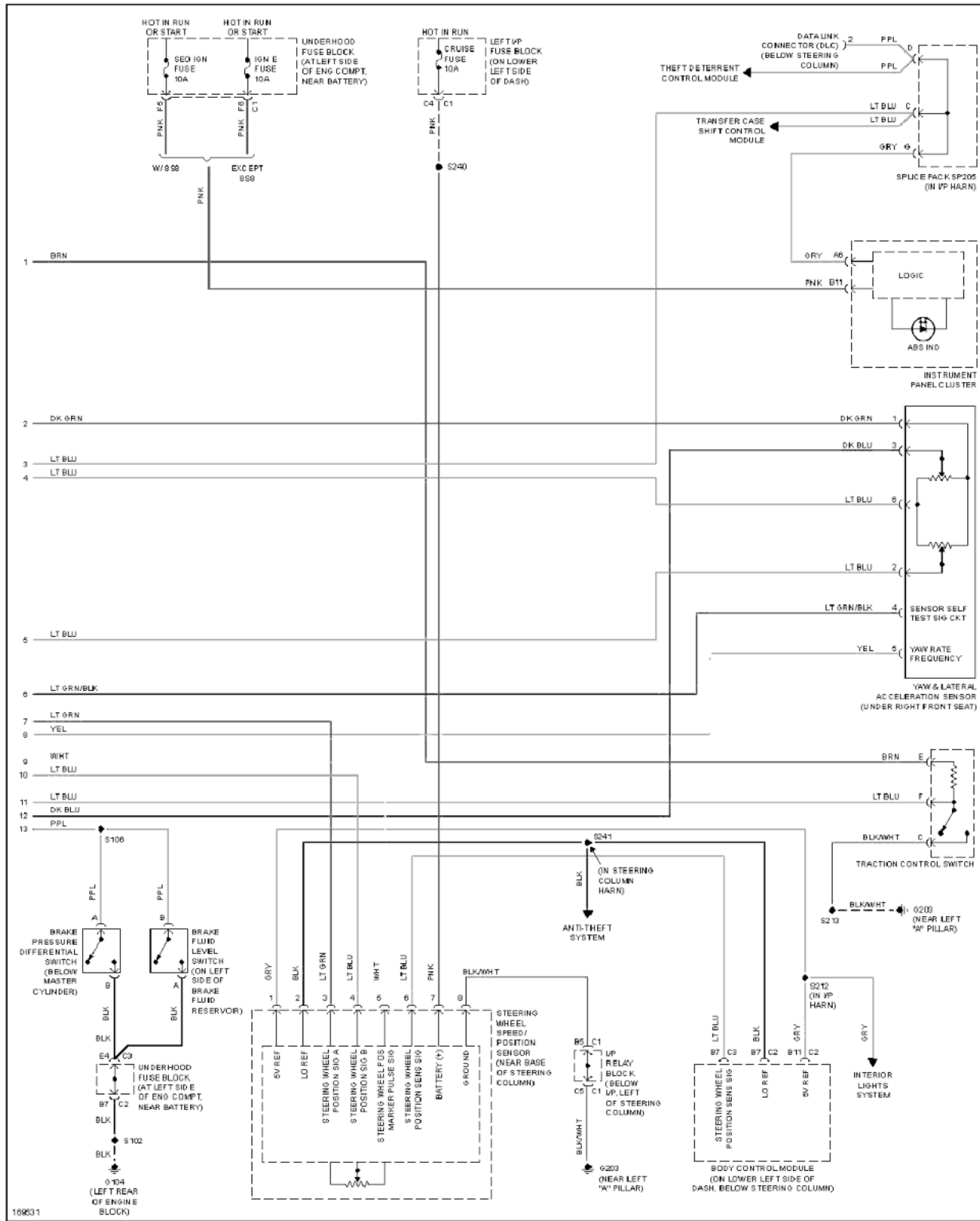

Fig. 10: Anti-lock Brakes Circuit, W/ Vehicle Speed Enhancement Stability (2 of 2)

# 2003 Chevrolet Suburban C1500

## 2003 SYSTEM WIRING DIAGRAMS Chevrolet - Suburban

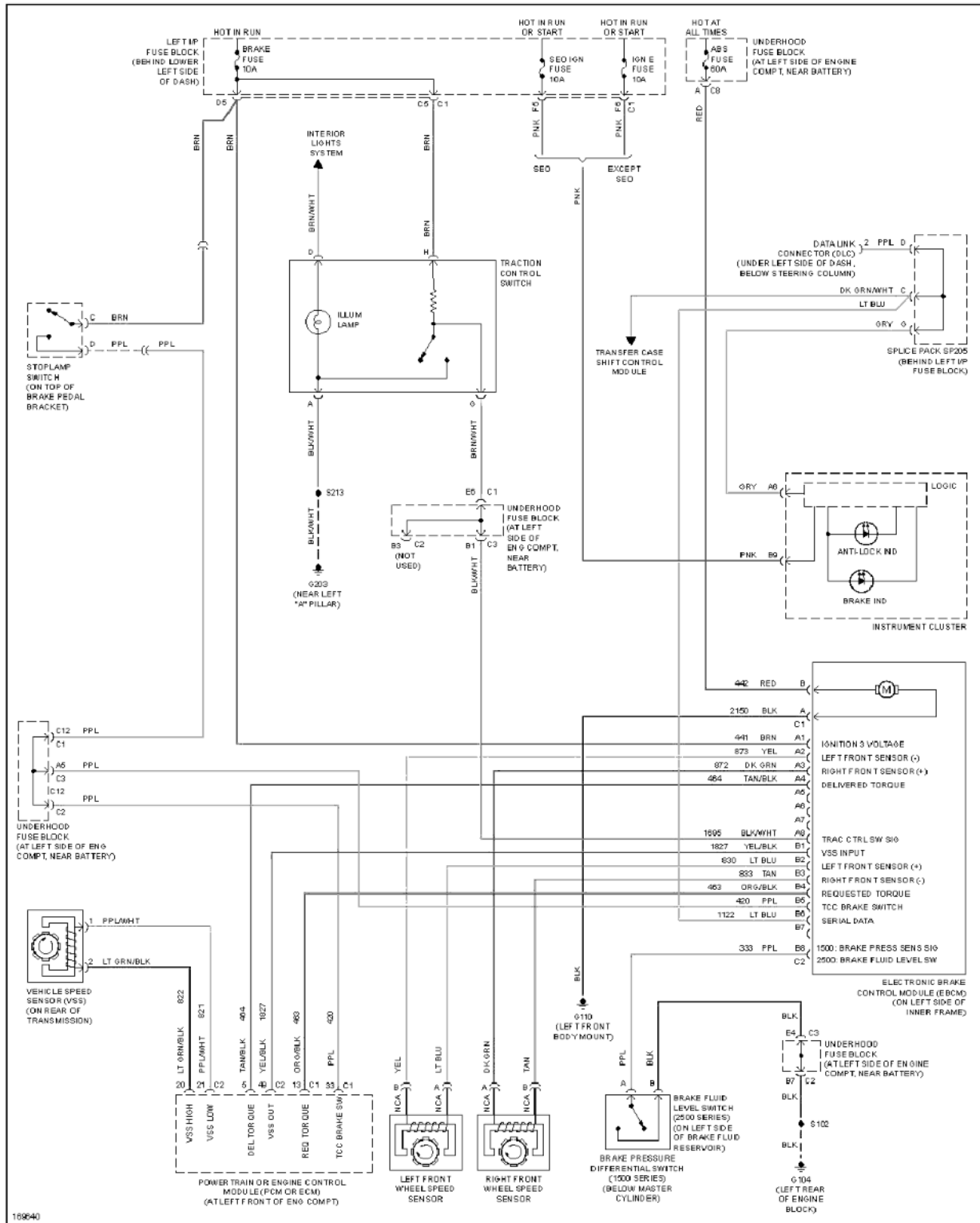
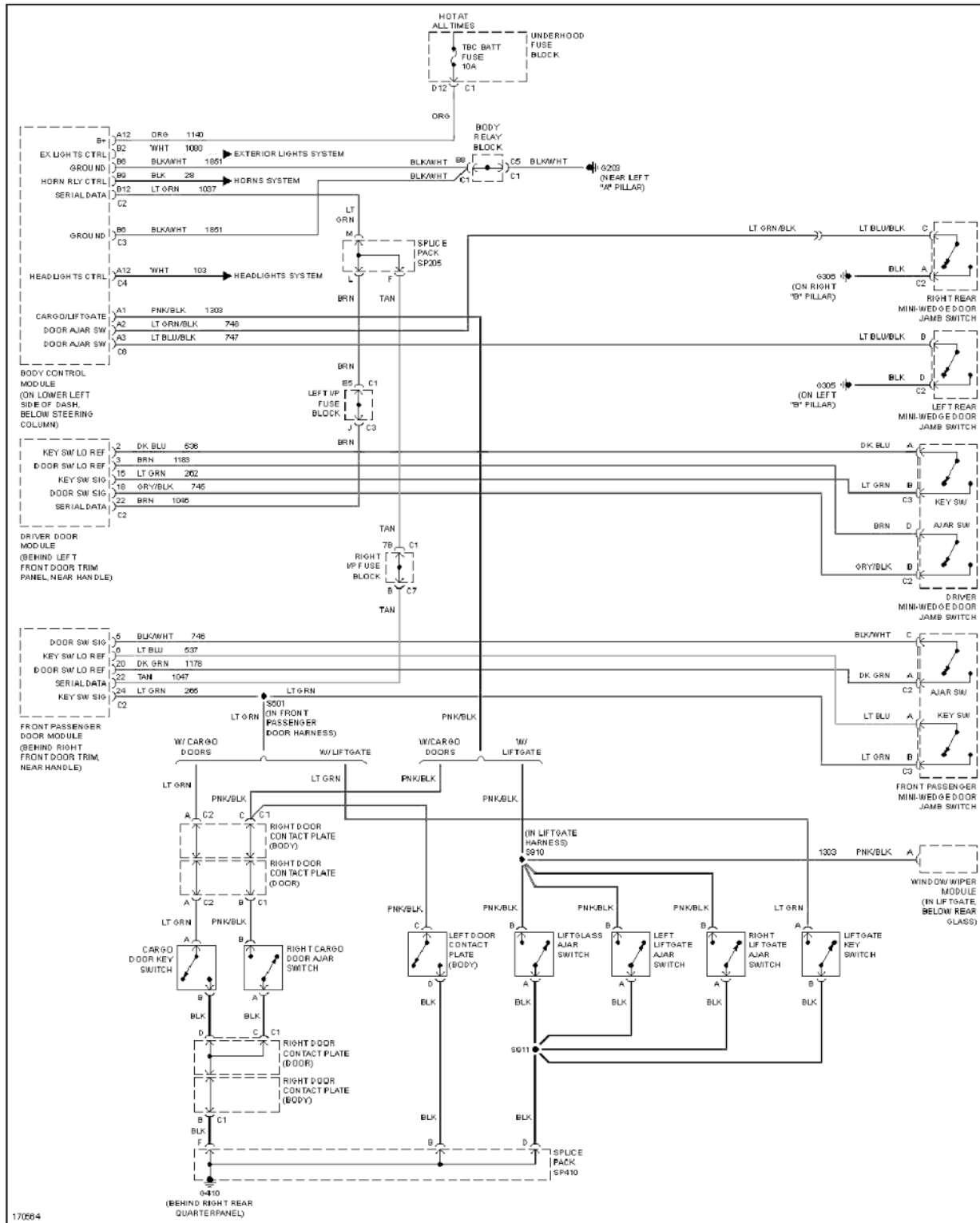

Fig. 11: Anti-lock Brakes Circuit, W/O Vehicle Speed Enhancement Stability

### ANTI-THEFT

# 2003 Chevrolet Suburban C1500

## 2003 SYSTEM WIRING DIAGRAMS Chevrolet - Suburban



**Fig. 12: Forced Entry Circuit**

# 2003 Chevrolet Suburban C1500

2003 SYSTEM WIRING DIAGRAMS Chevrolet - Suburban

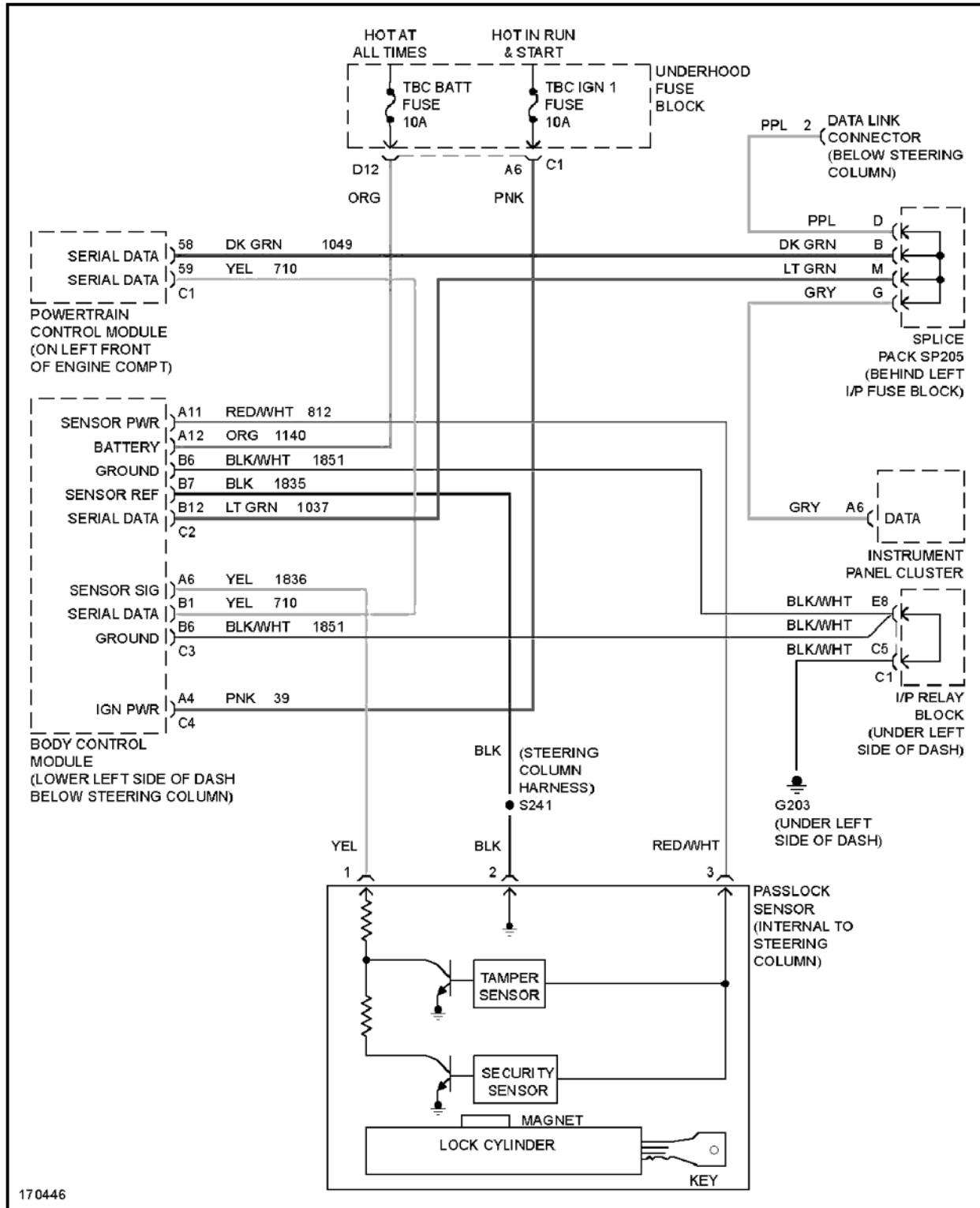

Fig. 13: Passlock Circuit

## BODY CONTROL MODULES



# 2003 Chevrolet Suburban C1500

## 2003 SYSTEM WIRING DIAGRAMS Chevrolet - Suburban

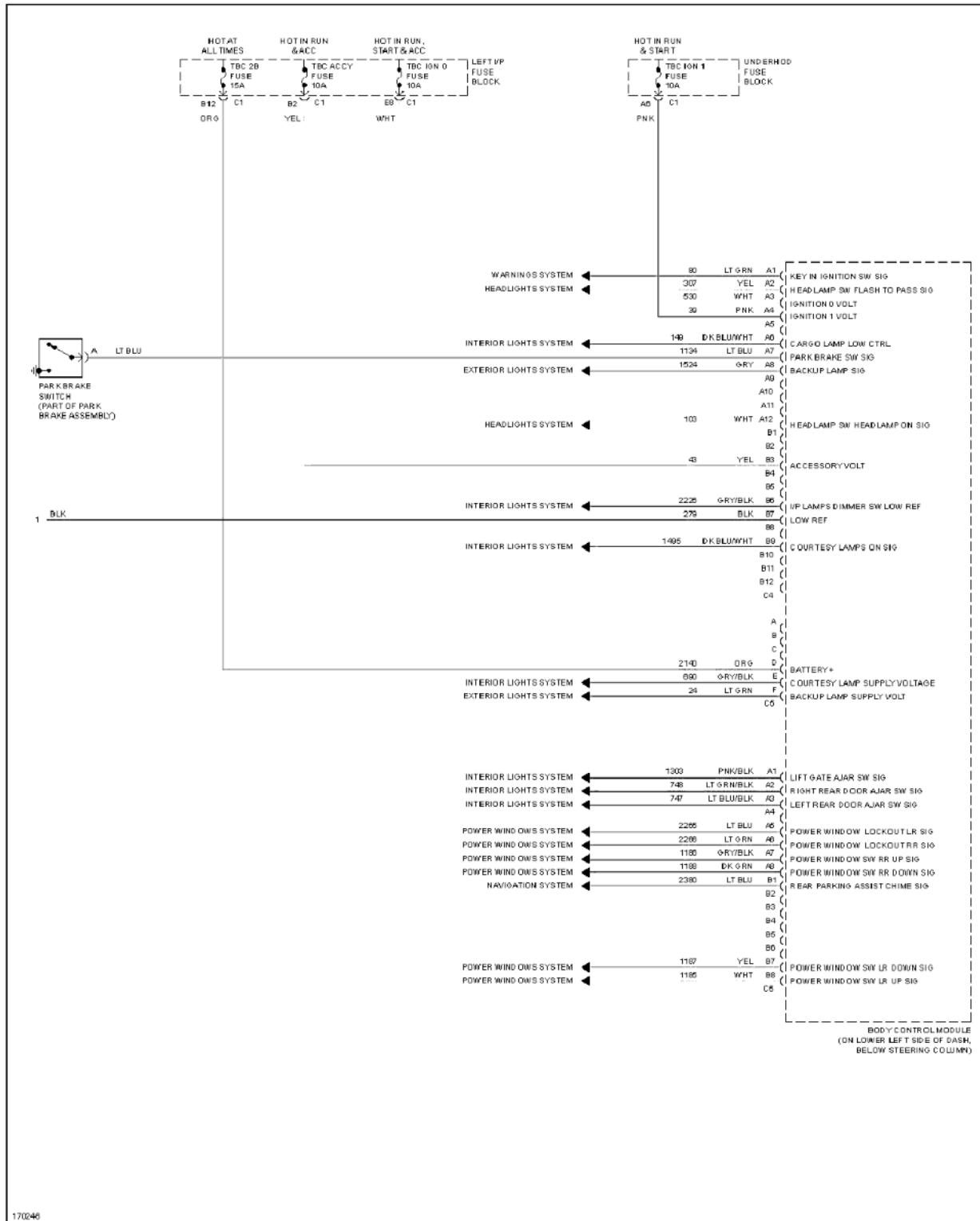

Fig. 15: Body Control Modules Circuit (2 of 2)

### COMPUTER DATA LINES

# 2003 Chevrolet Suburban C1500

## 2003 SYSTEM WIRING DIAGRAMS Chevrolet - Suburban

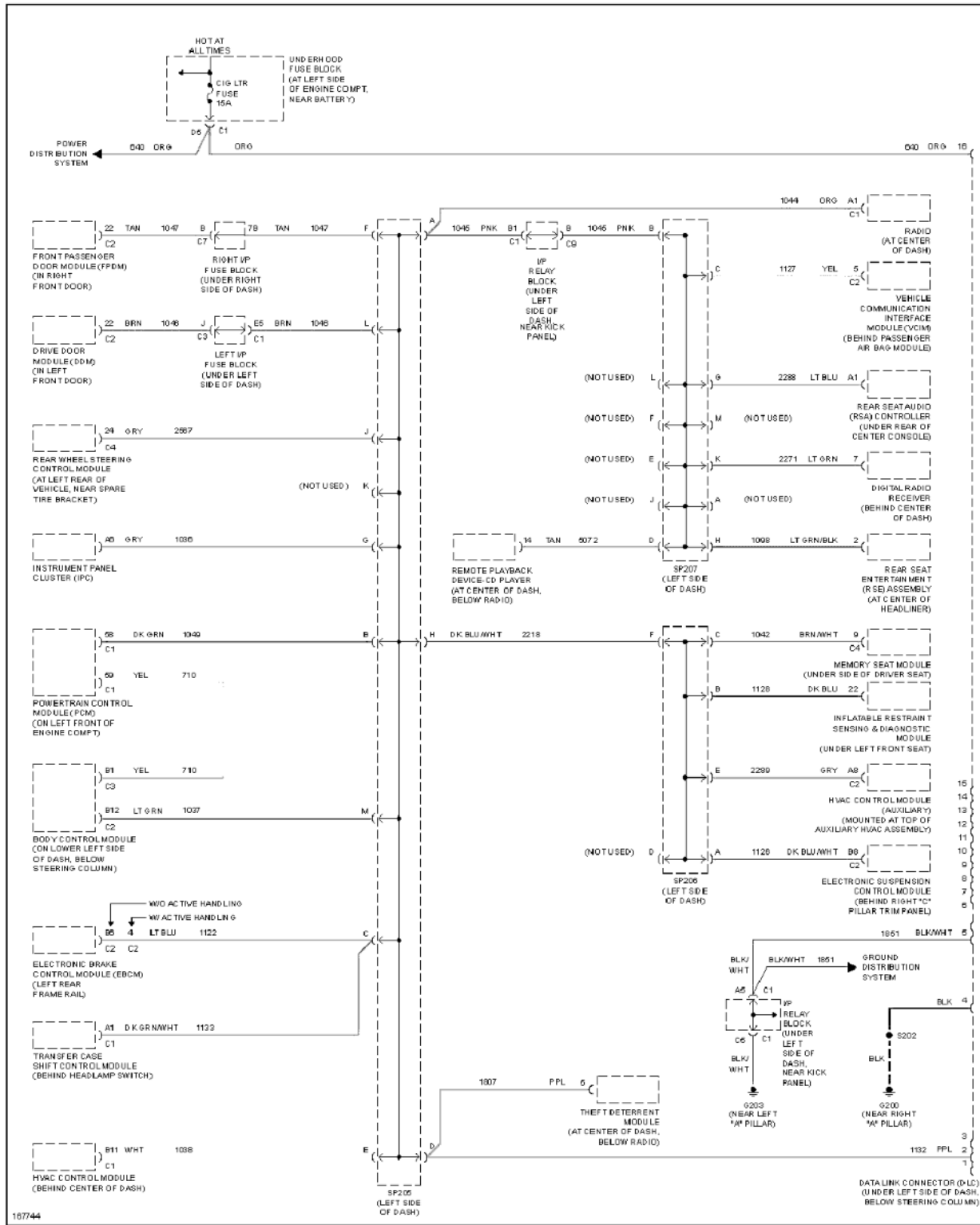

Fig. 16: Computer Data Lines Circuit, Base & Up-Level



# 2003 Chevrolet Suburban C1500

## 2003 SYSTEM WIRING DIAGRAMS Chevrolet - Suburban

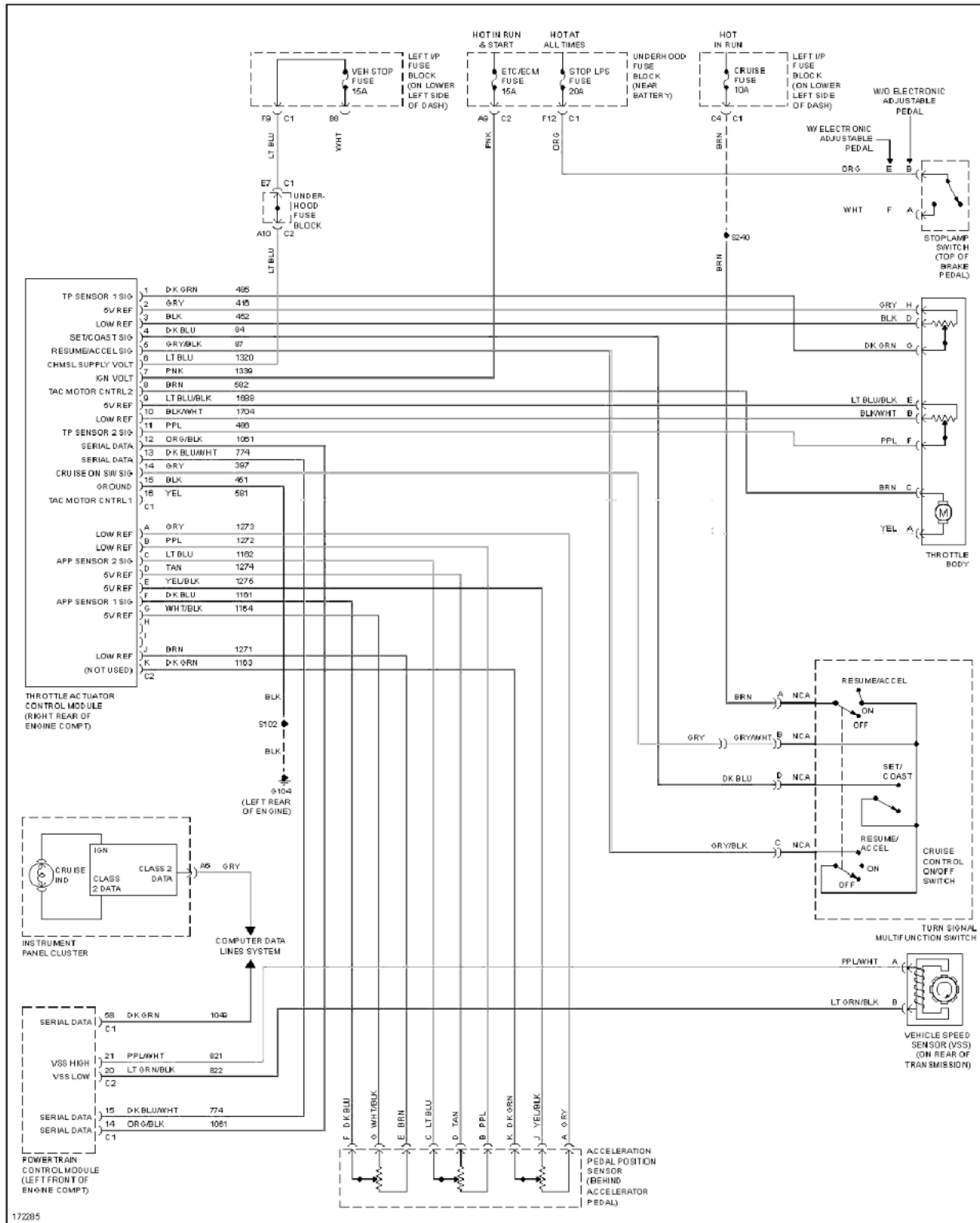
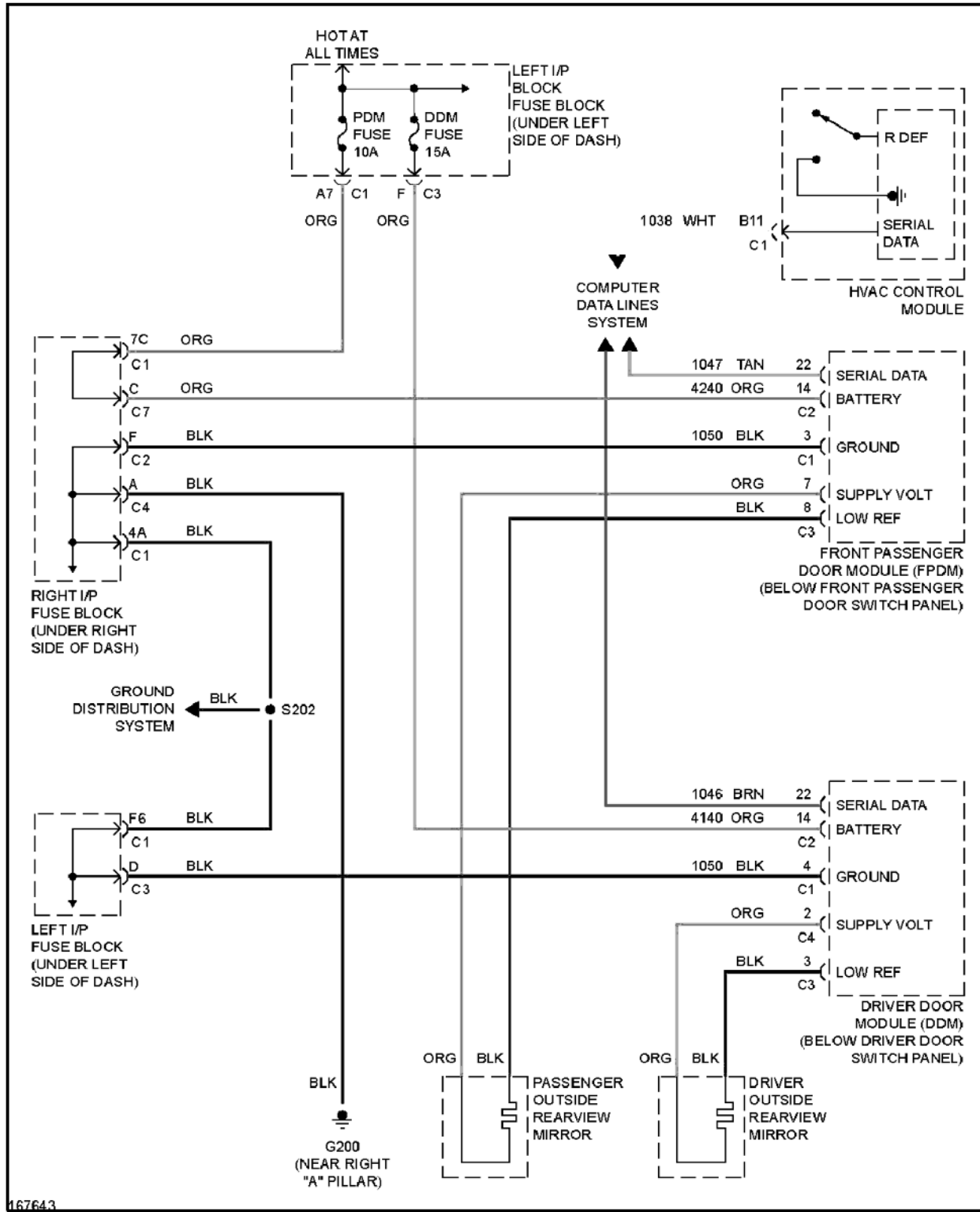

Fig. 18: Cruise Control Circuit

### DEFOGGERS

# 2003 Chevrolet Suburban C1500

2003 SYSTEM WIRING DIAGRAMS Chevrolet - Suburban



167643

**Fig. 19: Heated Mirrors Circuit**

# 2003 Chevrolet Suburban C1500

## 2003 SYSTEM WIRING DIAGRAMS Chevrolet - Suburban

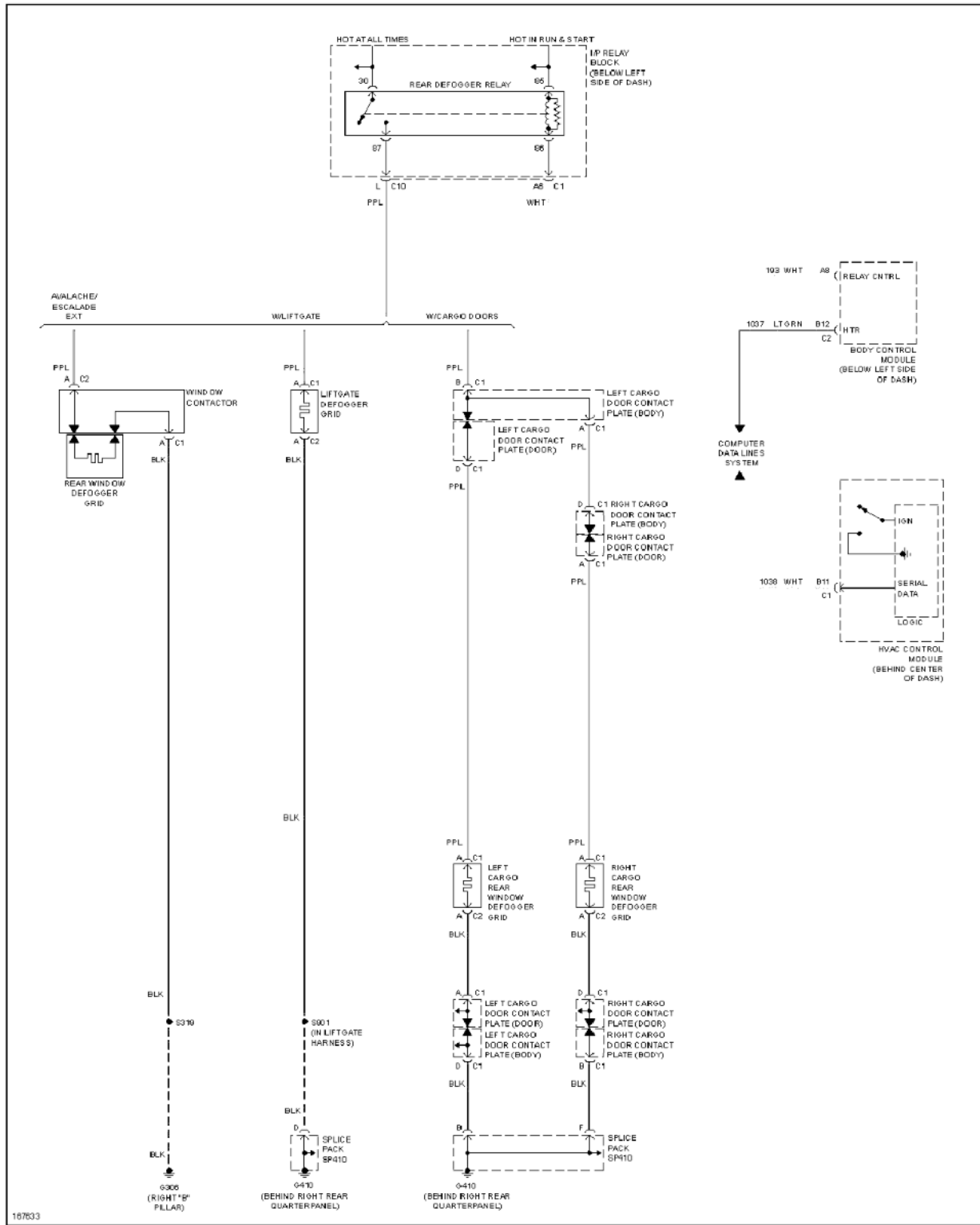
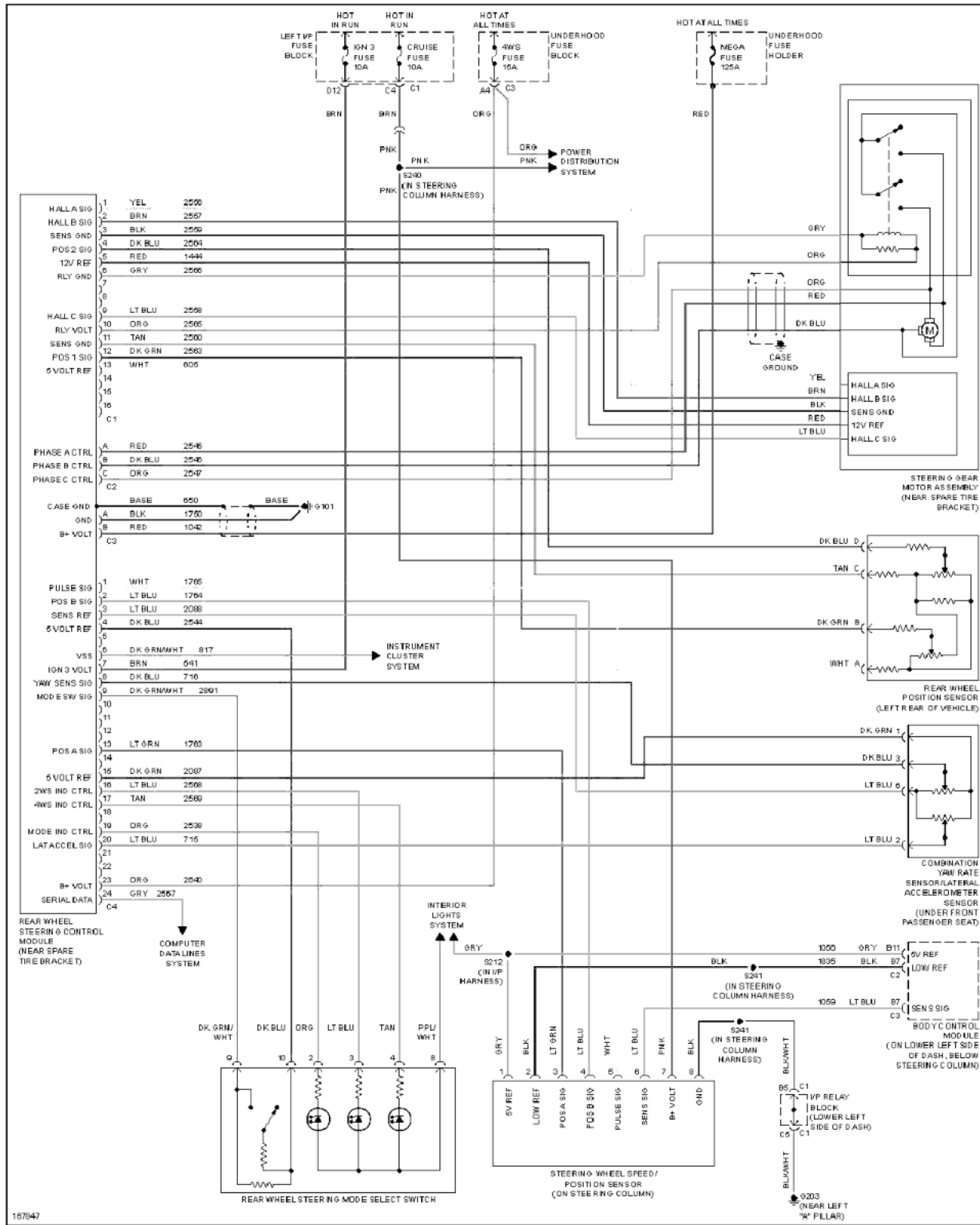

**Fig. 20: Rear Defogger Circuit**

### ELECTRONIC POWER STEERING

# 2003 Chevrolet Suburban C1500

## 2003 SYSTEM WIRING DIAGRAMS Chevrolet - Suburban



**Fig. 21: Rear Wheel Steering Circuit**  
**ELECTRONIC SUSPENSION**



# 2003 Chevrolet Suburban C1500

## 2003 SYSTEM WIRING DIAGRAMS Chevrolet - Suburban

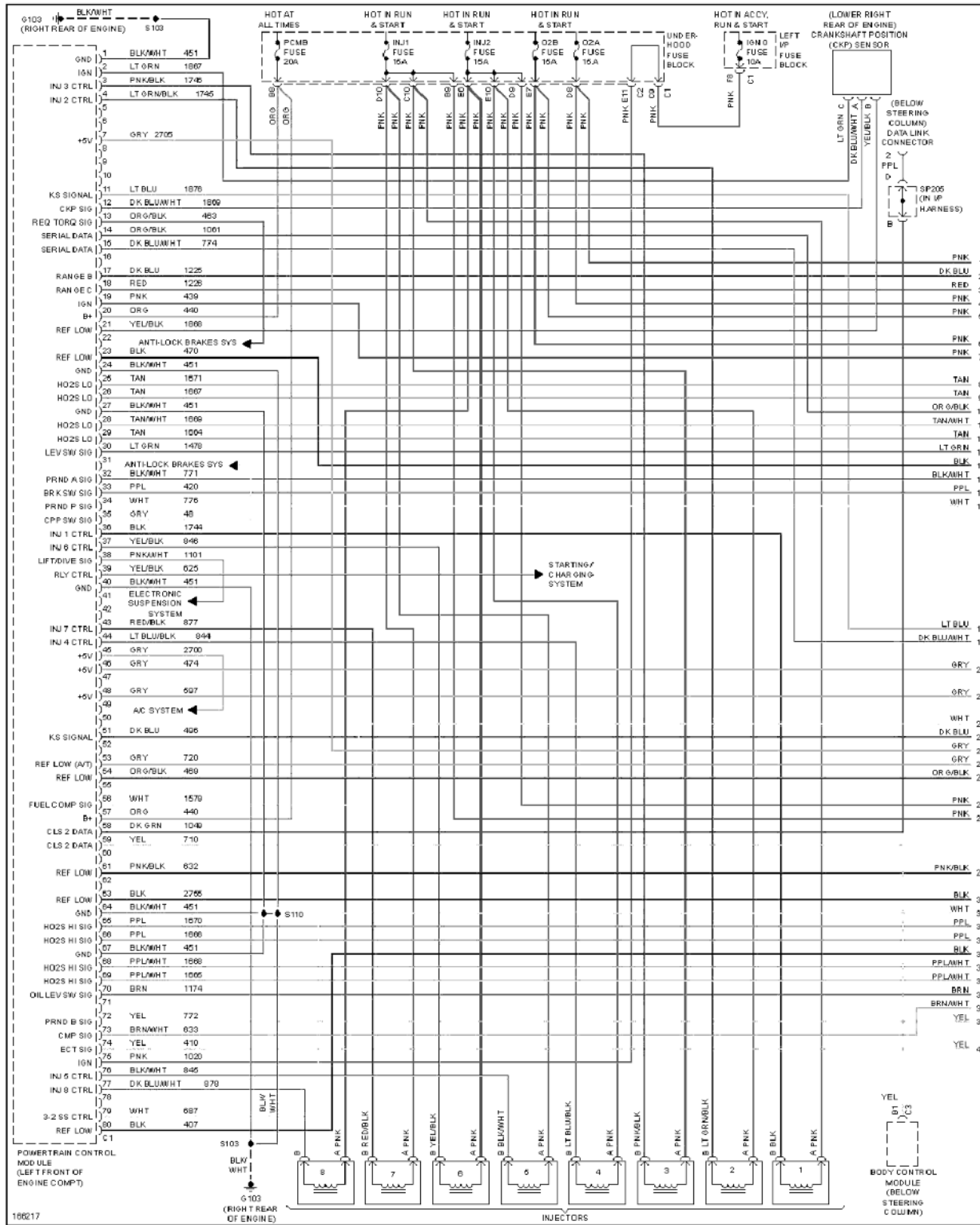

Fig. 23: 5.3L VIN T, Engine Performance Circuit (1 of 5)

# 2003 Chevrolet Suburban C1500

## 2003 SYSTEM WIRING DIAGRAMS Chevrolet - Suburban

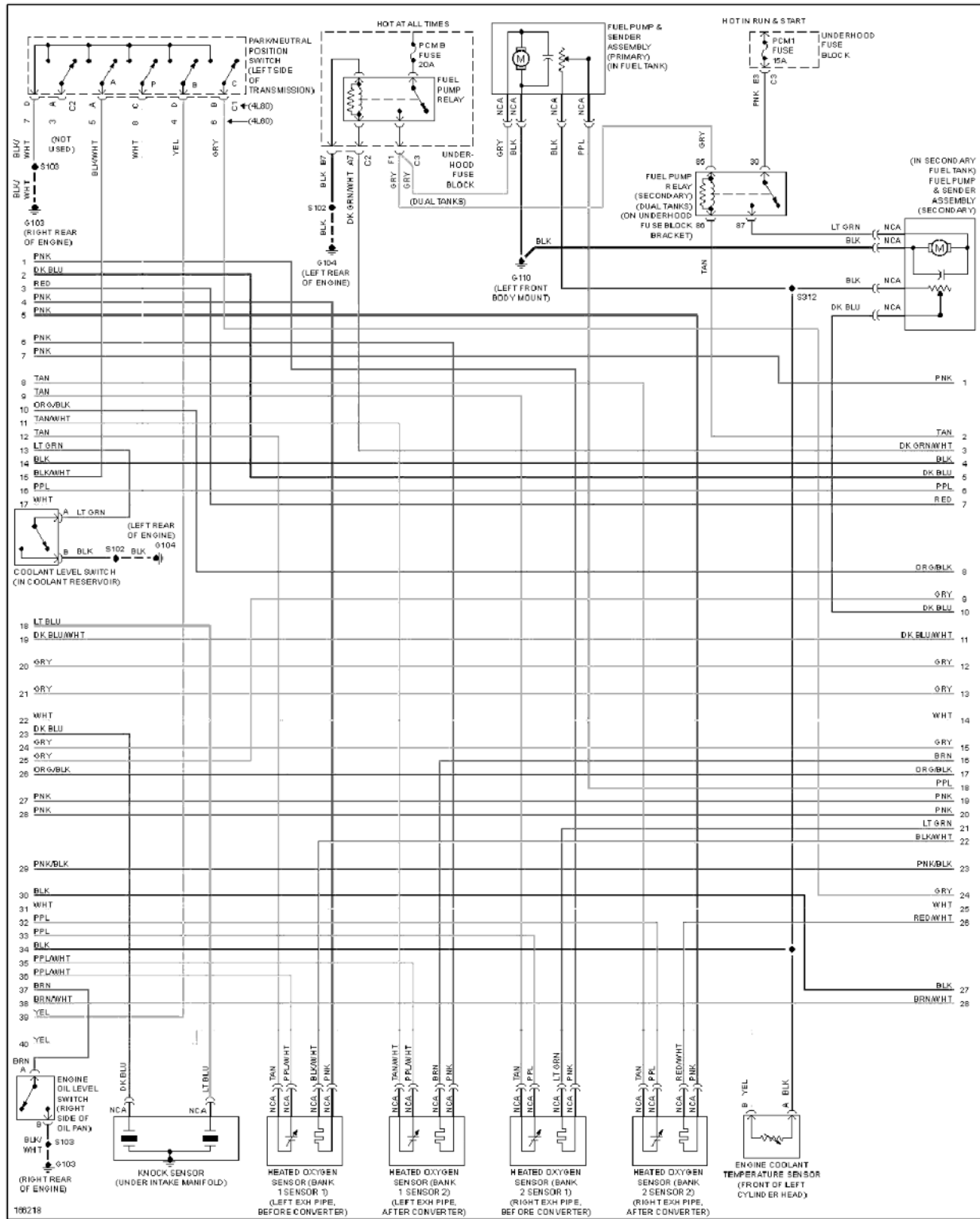

Fig. 24: 5.3L VIN T, Engine Performance Circuit (2 of 5)

# 2003 Chevrolet Suburban C1500

## 2003 SYSTEM WIRING DIAGRAMS Chevrolet - Suburban

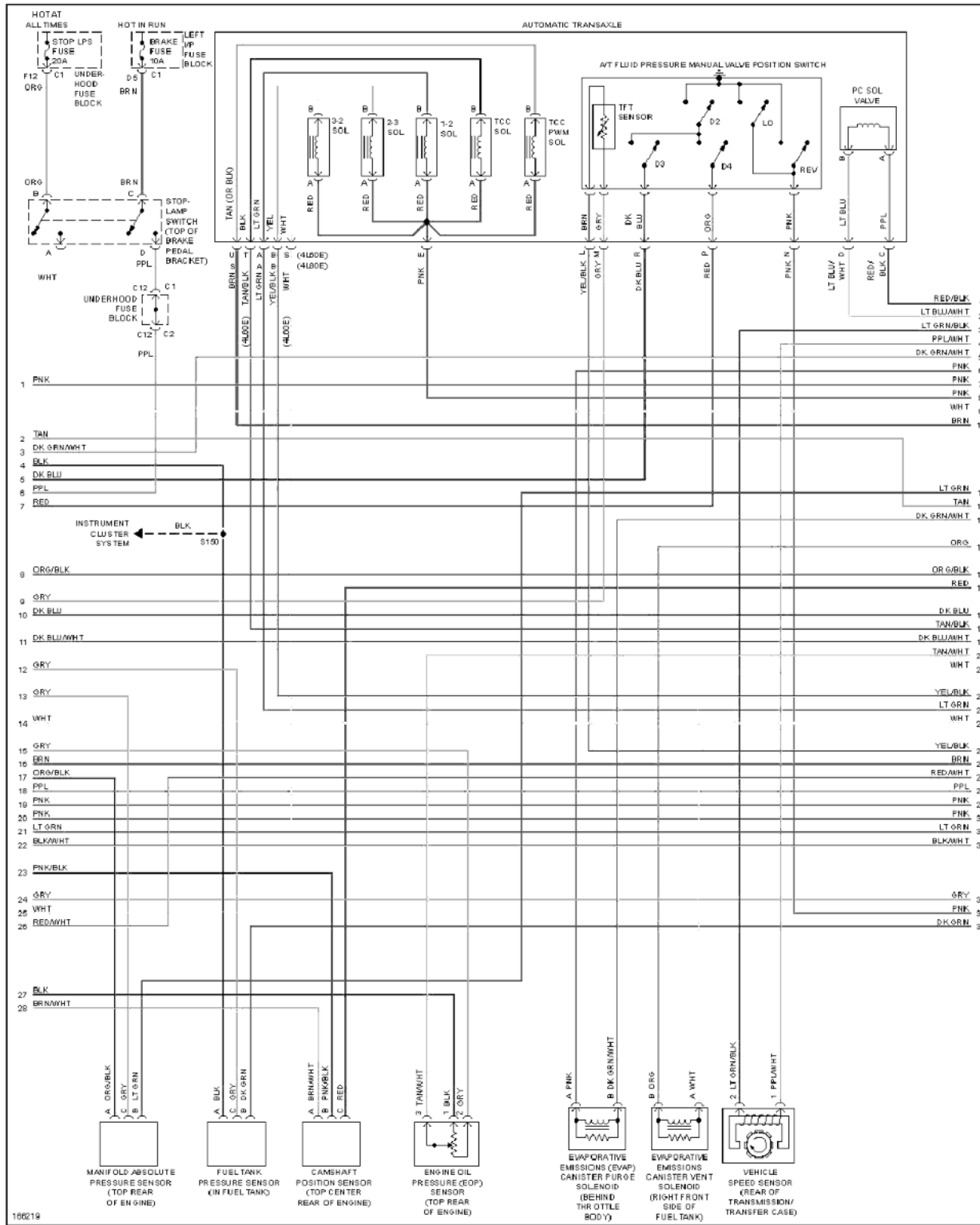

Fig. 25: 5.3L VIN T, Engine Performance Circuit (3 of 5)

# 2003 Chevrolet Suburban C1500

## 2003 SYSTEM WIRING DIAGRAMS Chevrolet - Suburban

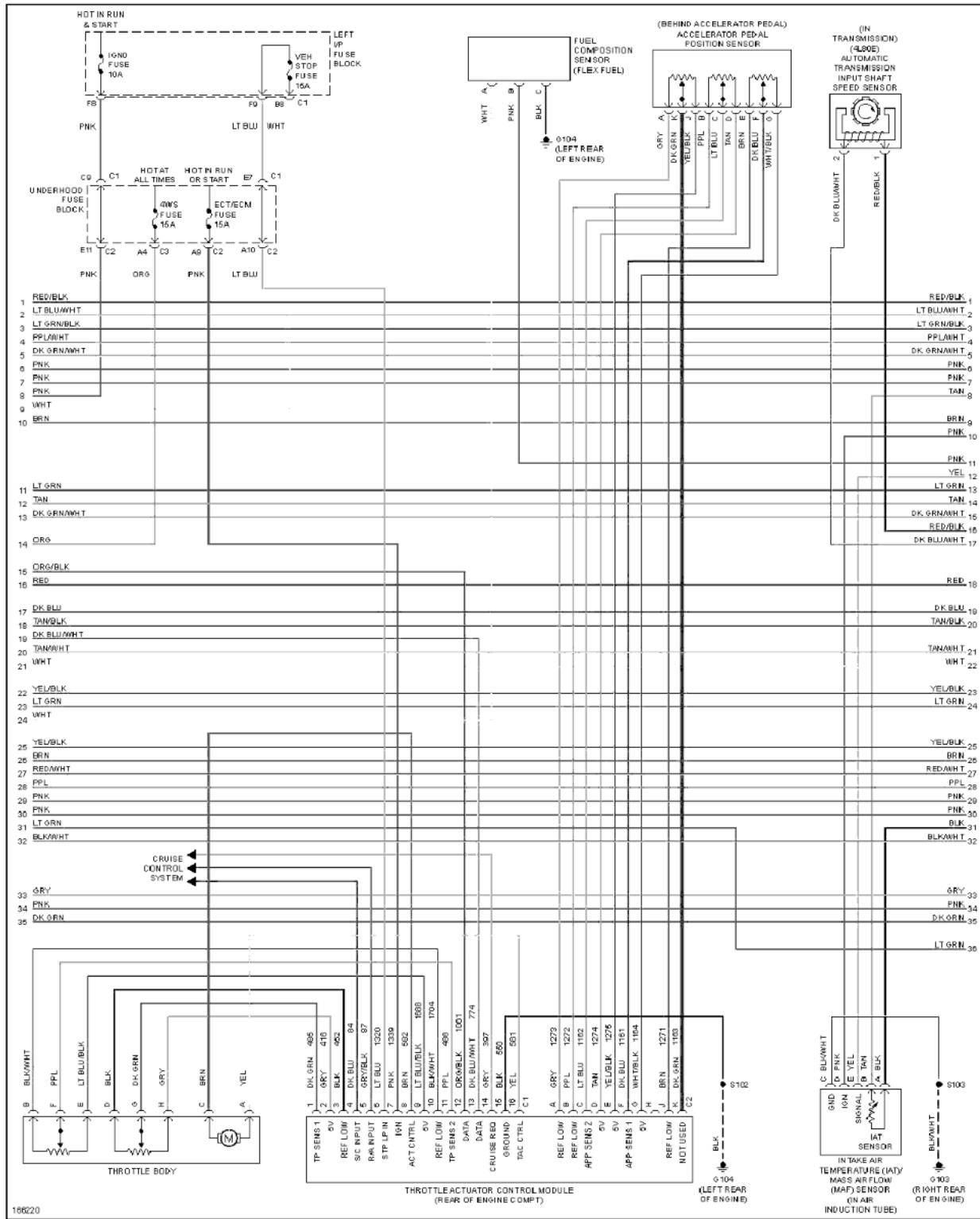

Fig. 26: 5.3L VIN T, Engine Performance Circuit (4 of 5)

# 2003 Chevrolet Suburban C1500

## 2003 SYSTEM WIRING DIAGRAMS Chevrolet - Suburban

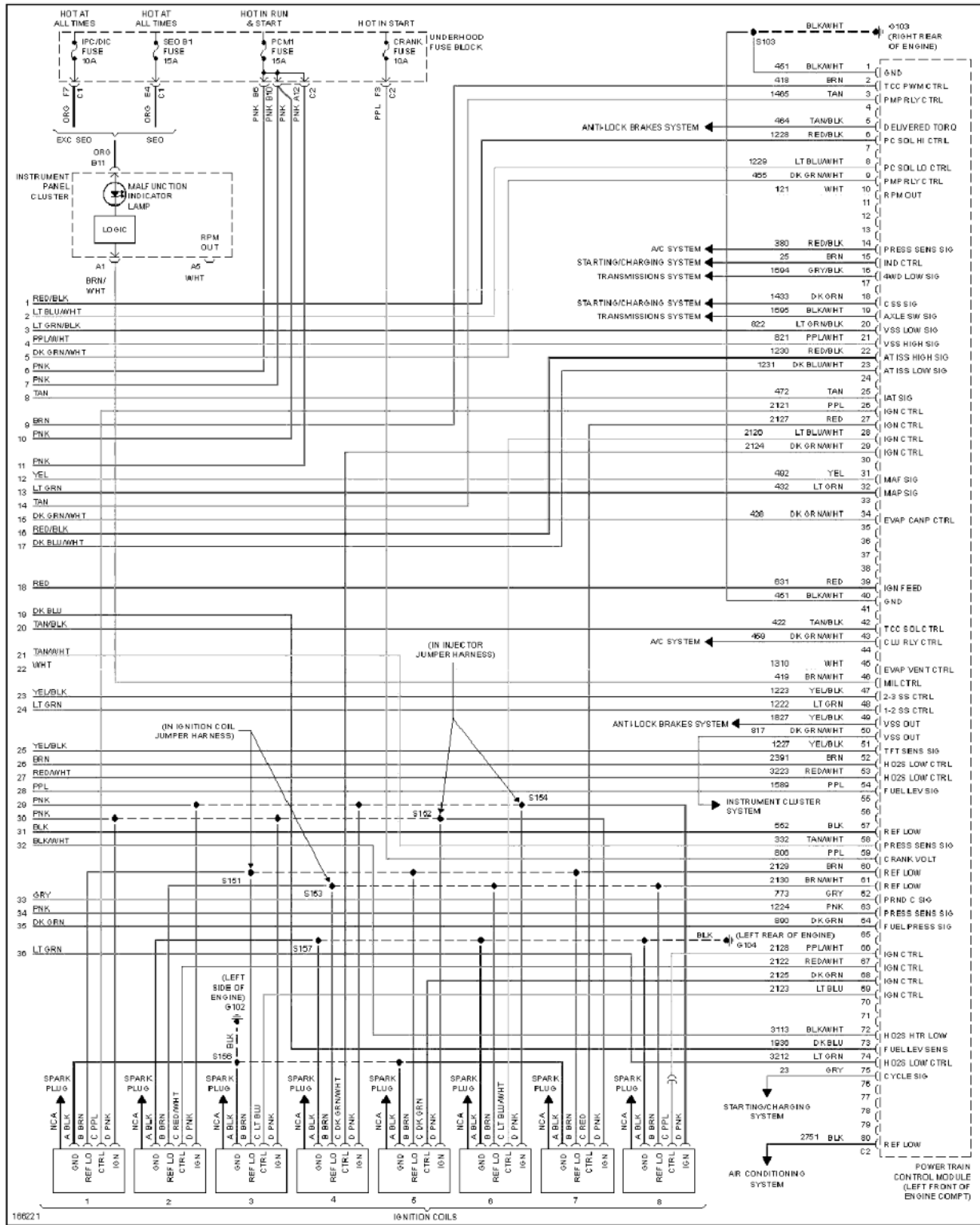

Fig. 27: 5.3L VIN T, Engine Performance Circuit (5 of 5)

5.3L VIN Z

# 2003 Chevrolet Suburban C1500

## 2003 SYSTEM WIRING DIAGRAMS Chevrolet - Suburban

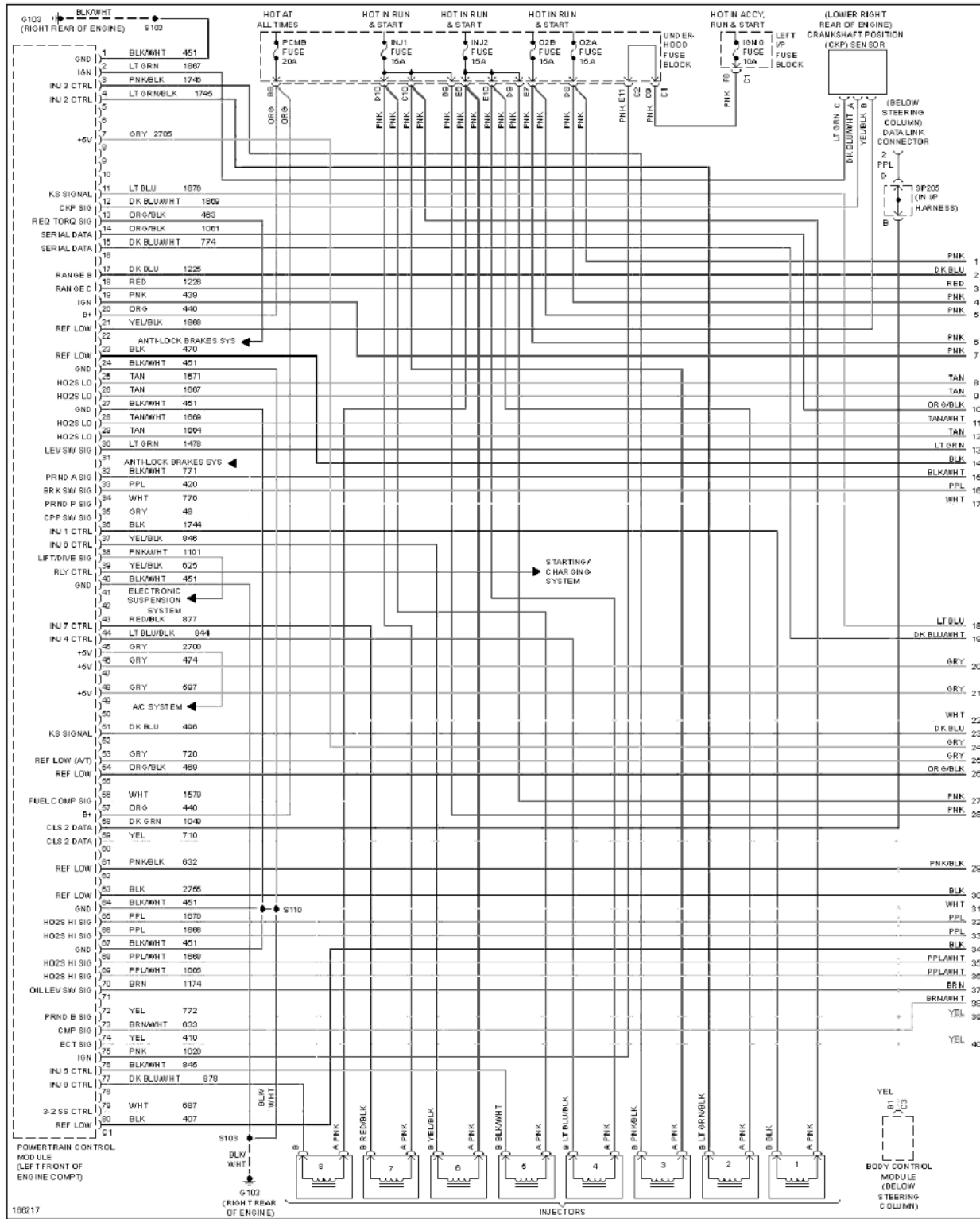

Fig. 28: 5.3L VIN Z, Engine Performance Circuit (1 of 5)

# 2003 Chevrolet Suburban C1500

## 2003 SYSTEM WIRING DIAGRAMS Chevrolet - Suburban

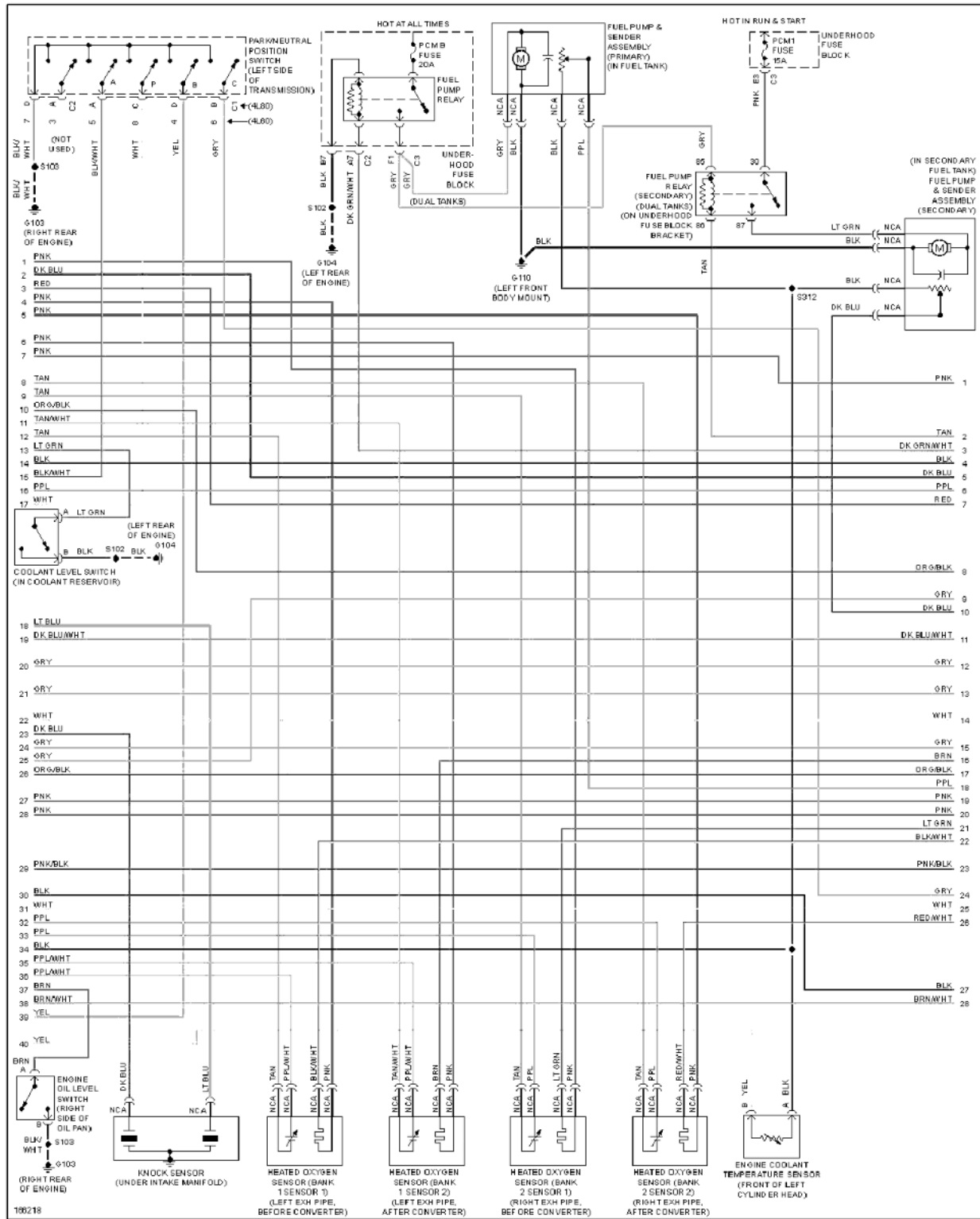

Fig. 29: 5.3L VIN Z, Engine Performance Circuit (2 of 5)

# 2003 Chevrolet Suburban C1500

## 2003 SYSTEM WIRING DIAGRAMS Chevrolet - Suburban

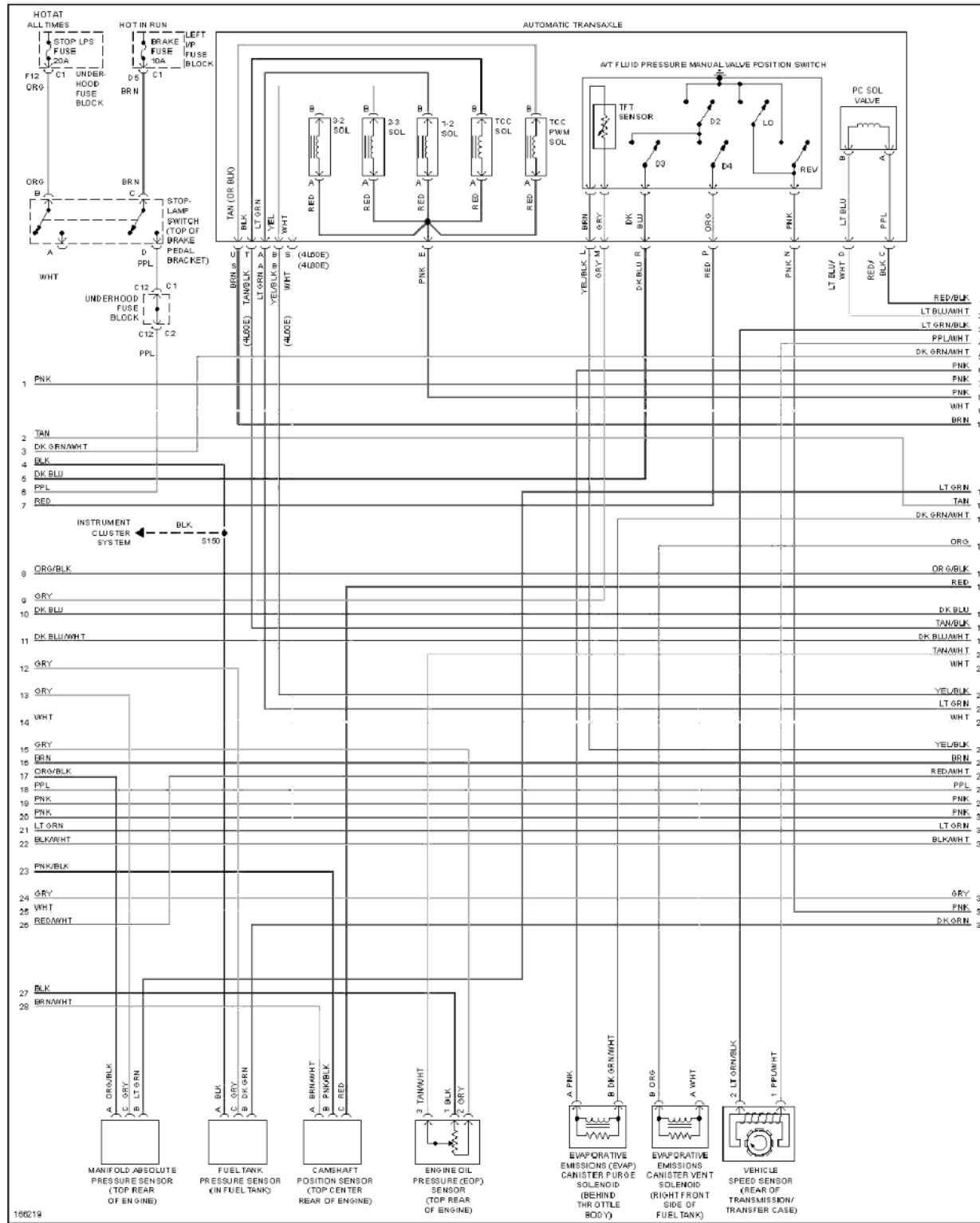

Fig. 30: 5.3L VIN Z, Engine Performance Circuit (3 of 5)

# 2003 Chevrolet Suburban C1500

## 2003 SYSTEM WIRING DIAGRAMS Chevrolet - Suburban

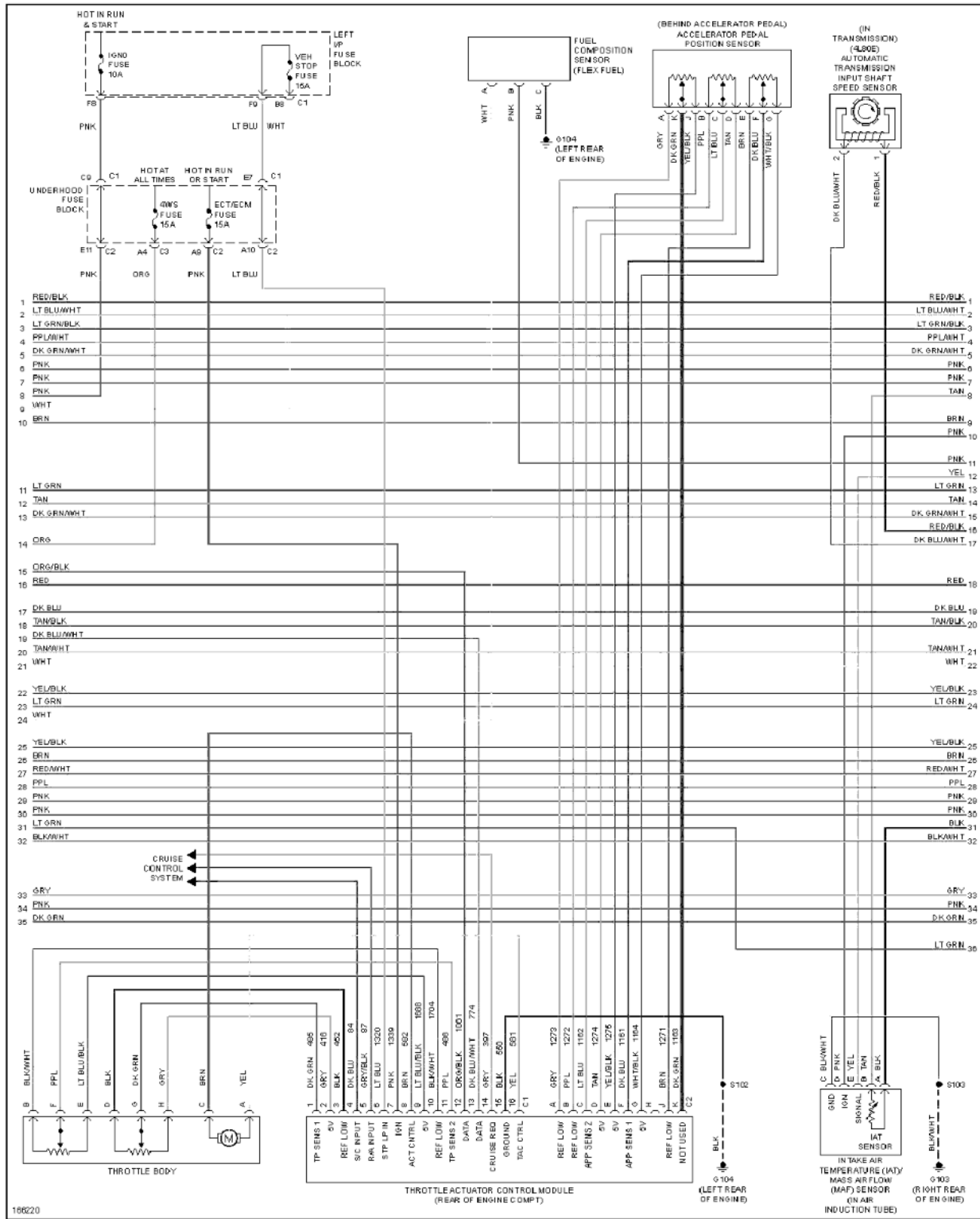

Fig. 31: 5.3L VIN Z, Engine Performance Circuit (4 of 5)

# 2003 Chevrolet Suburban C1500

## 2003 SYSTEM WIRING DIAGRAMS Chevrolet - Suburban

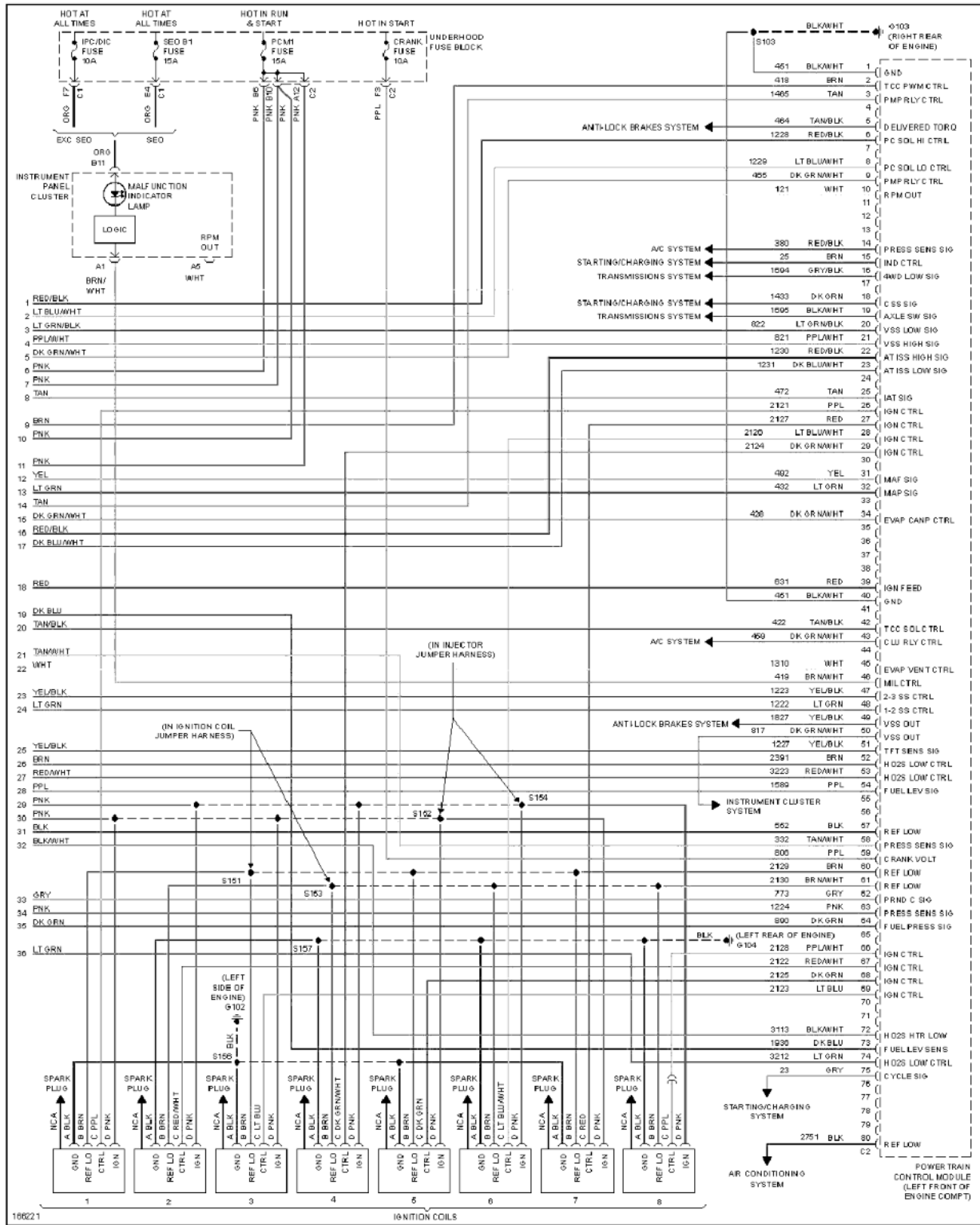

Fig. 32: 5.3L VIN Z, Engine Performance Circuit (5 of 5)

6.0L VIN U

# 2003 Chevrolet Suburban C1500

## 2003 SYSTEM WIRING DIAGRAMS Chevrolet - Suburban

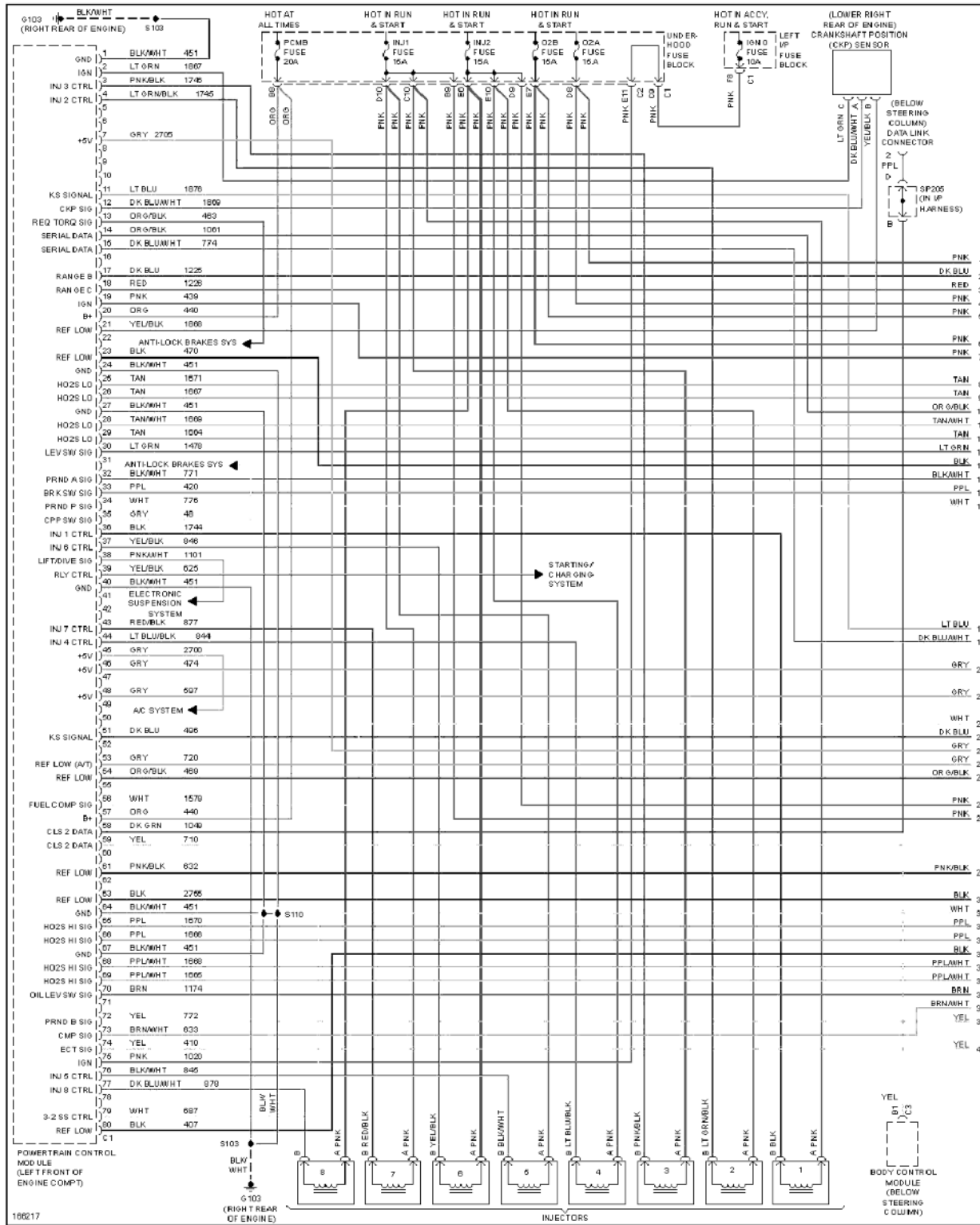

Fig. 33: 6.0L VIN U, Engine Performance Circuit (1 of 5)

# 2003 Chevrolet Suburban C1500

## 2003 SYSTEM WIRING DIAGRAMS Chevrolet - Suburban

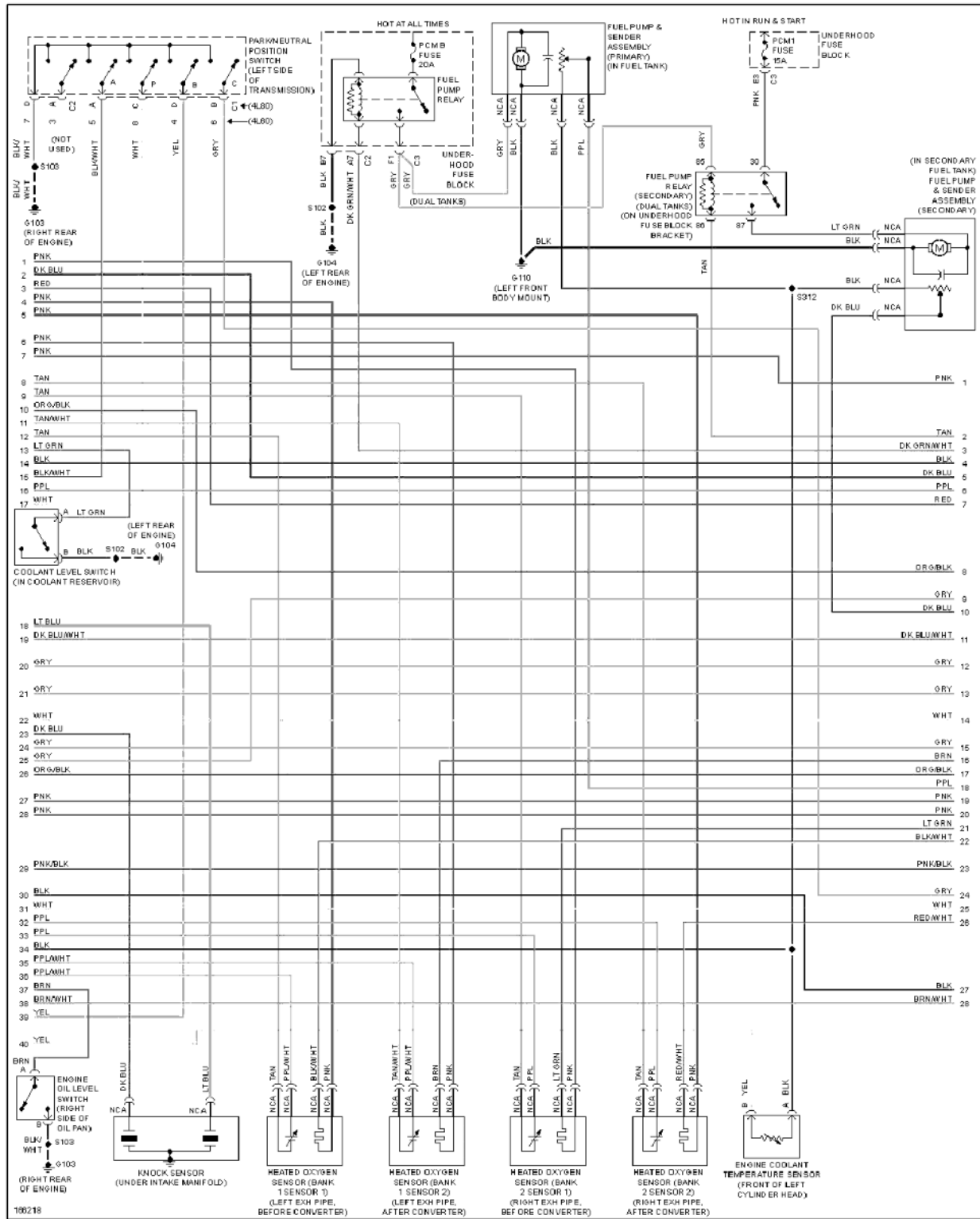

Fig. 34: 6.0L VIN U, Engine Performance Circuit (2 of 5)

# 2003 Chevrolet Suburban C1500

## 2003 SYSTEM WIRING DIAGRAMS Chevrolet - Suburban

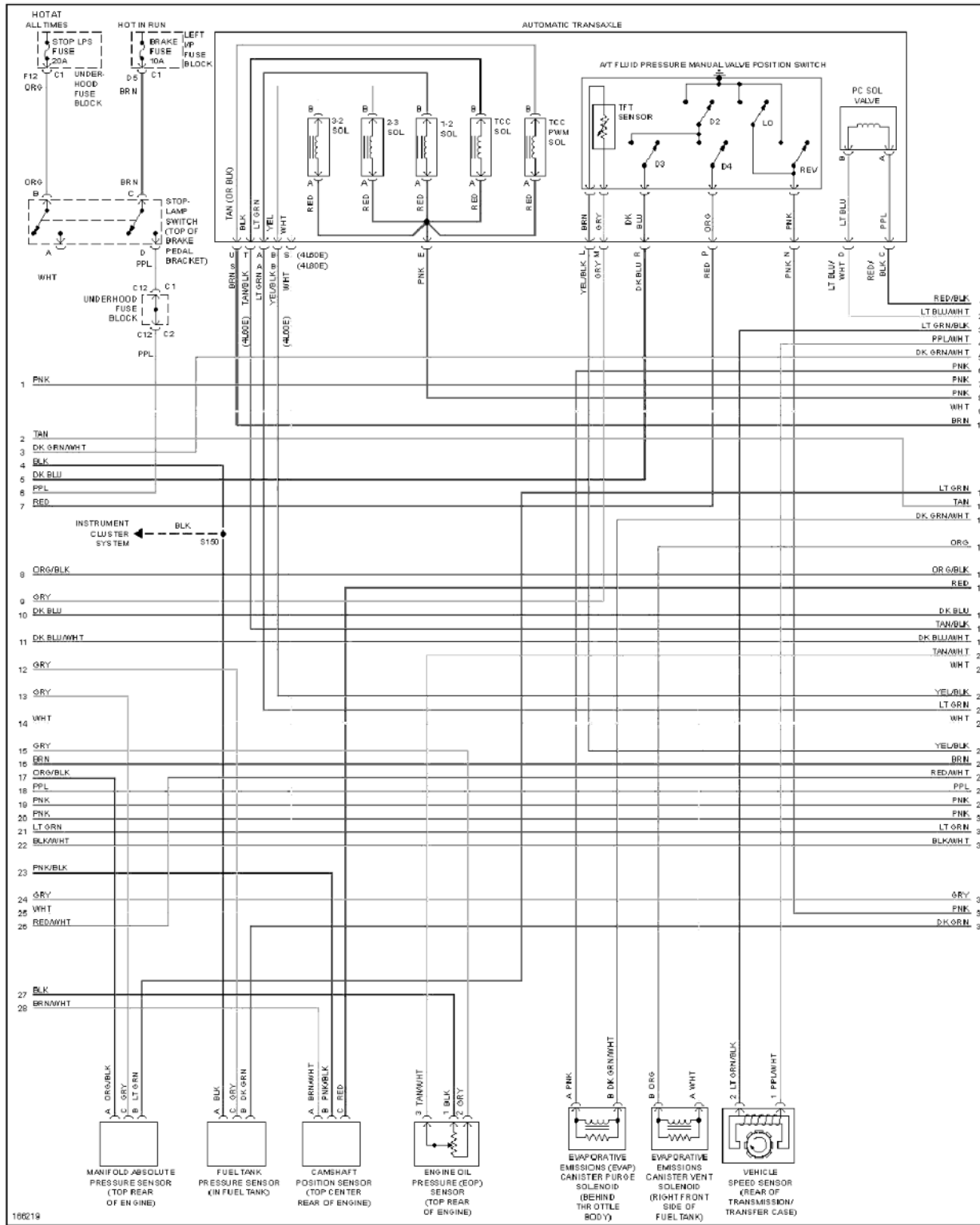

Fig. 35: 6.0L VIN U, Engine Performance Circuit (3 of 5)

# 2003 Chevrolet Suburban C1500

## 2003 SYSTEM WIRING DIAGRAMS Chevrolet - Suburban

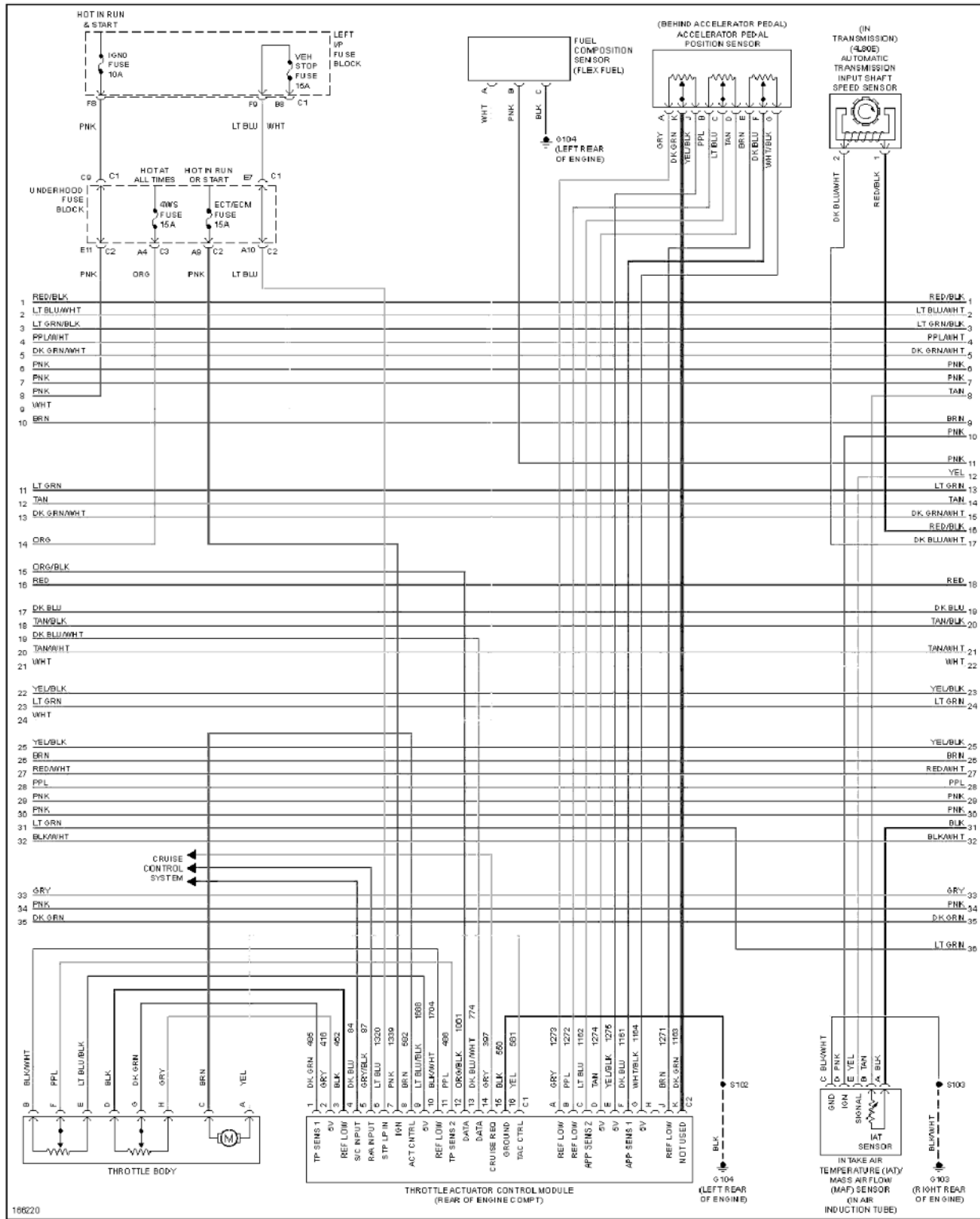

Fig. 36: 6.0L VIN U, Engine Performance Circuit (4 of 5)

# 2003 Chevrolet Suburban C1500

## 2003 SYSTEM WIRING DIAGRAMS Chevrolet - Suburban

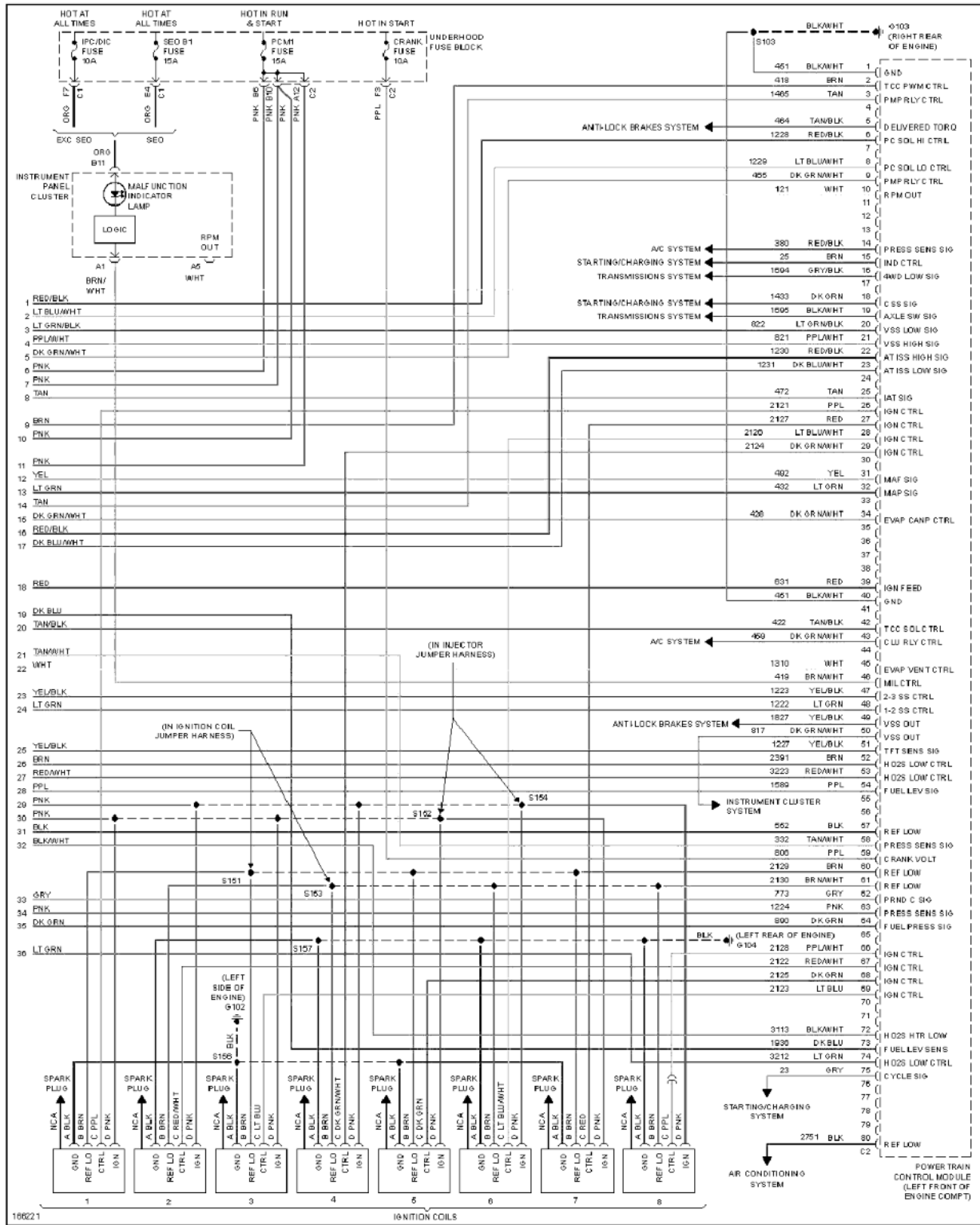

Fig. 37: 6.0L VIN U, Engine Performance Circuit (5 of 5)

8.1L VIN G

# 2003 Chevrolet Suburban C1500

## 2003 SYSTEM WIRING DIAGRAMS Chevrolet - Suburban

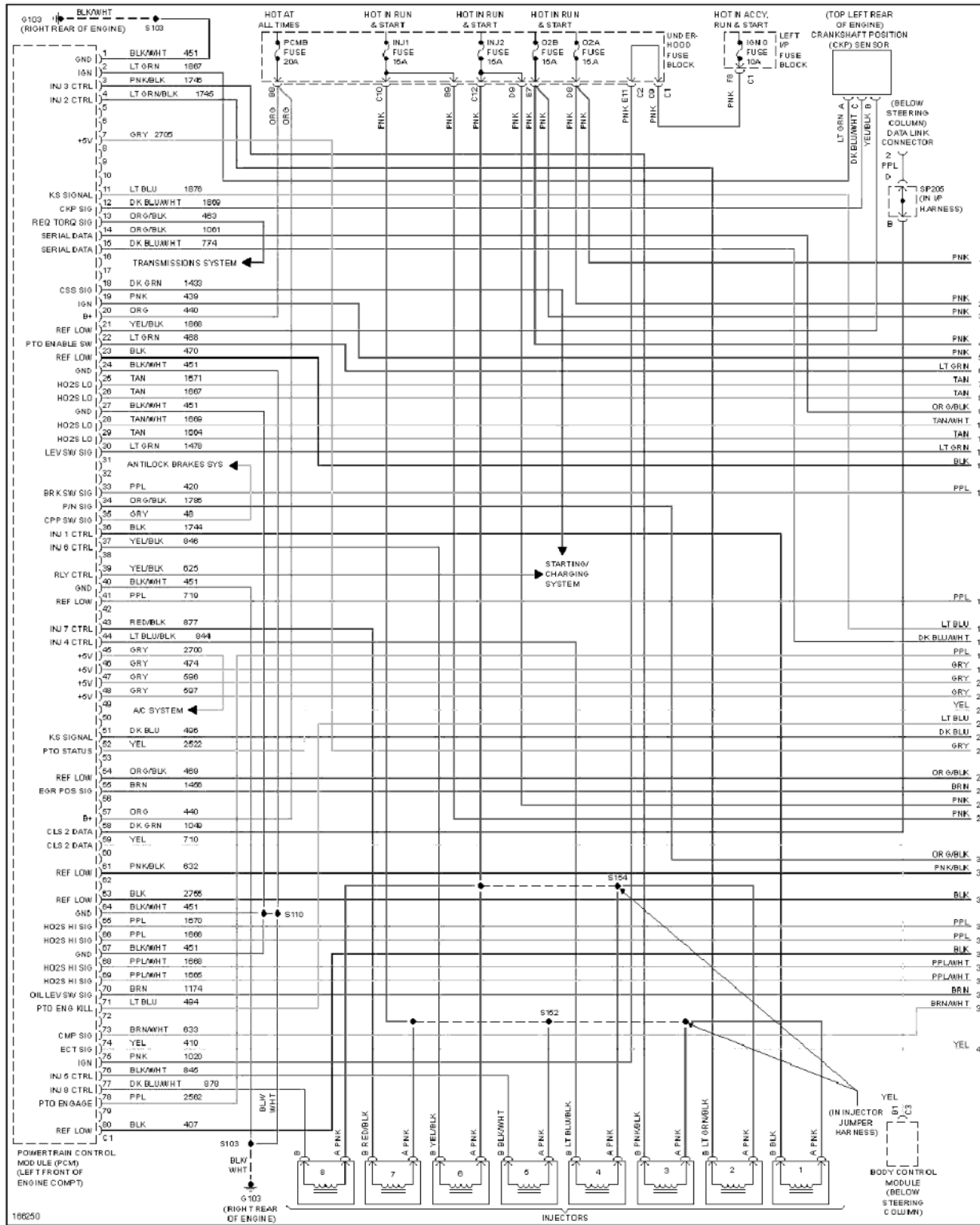
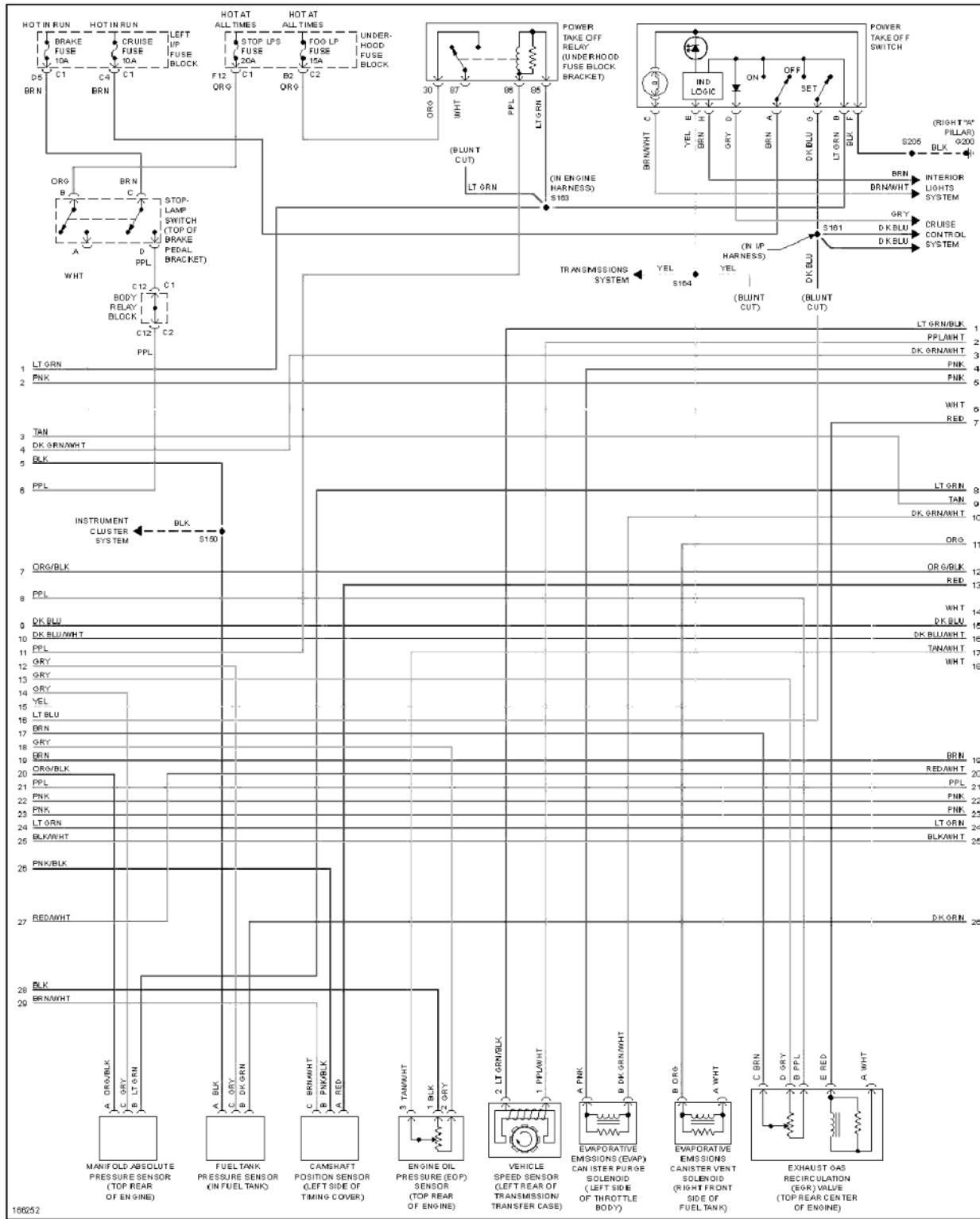

Fig. 38: 8.1L VIN G, Engine Performance Circuit (1 of 5)



# 2003 Chevrolet Suburban C1500

## 2003 SYSTEM WIRING DIAGRAMS Chevrolet - Suburban



**Fig. 40: 8.1L VIN G, Engine Performance Circuit (3 of 5)**

# 2003 Chevrolet Suburban C1500

## 2003 SYSTEM WIRING DIAGRAMS Chevrolet - Suburban

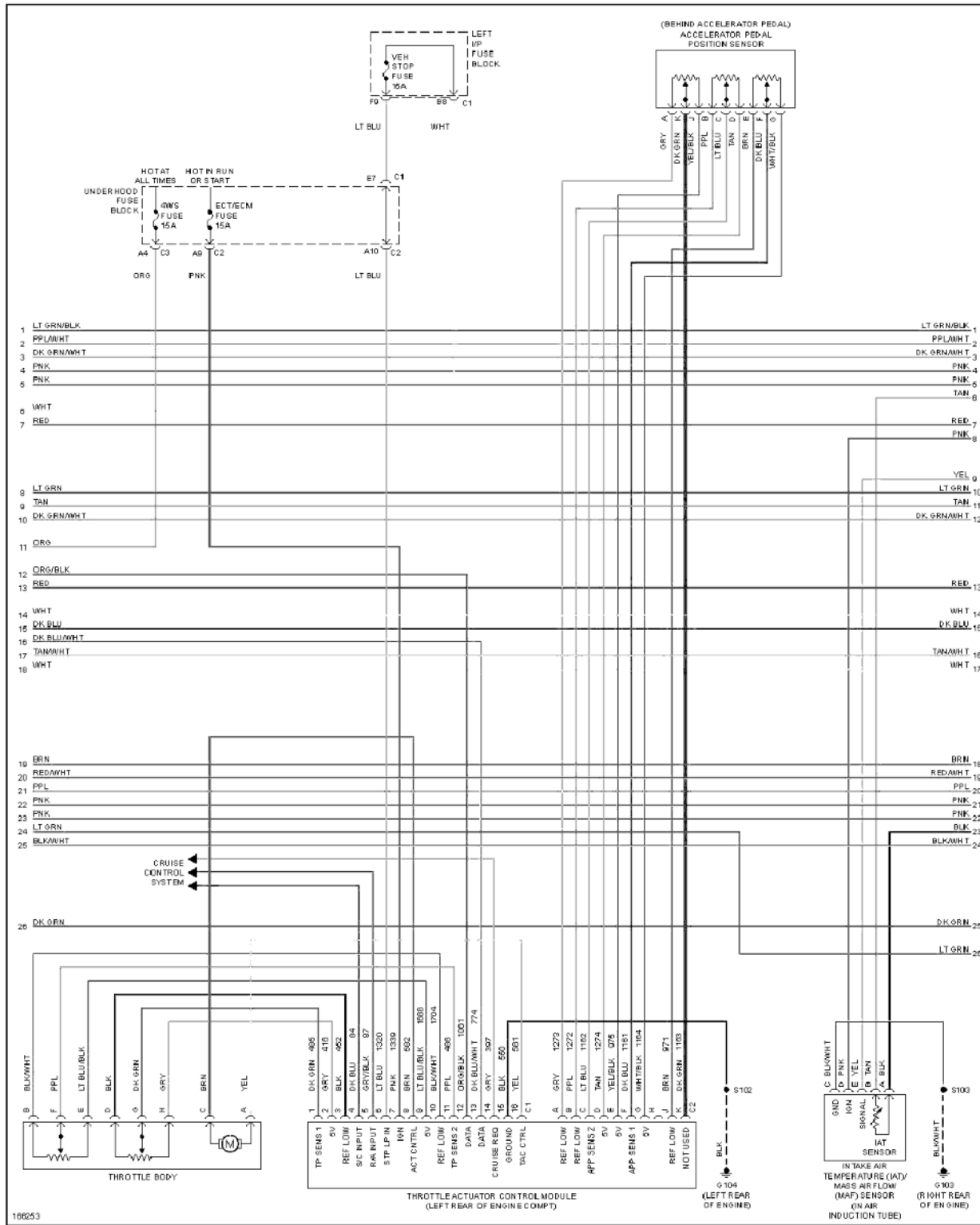

Fig. 41: 8.1L VIN G, Engine Performance Circuit (4 of 5)

# 2003 Chevrolet Suburban C1500

## 2003 SYSTEM WIRING DIAGRAMS Chevrolet - Suburban

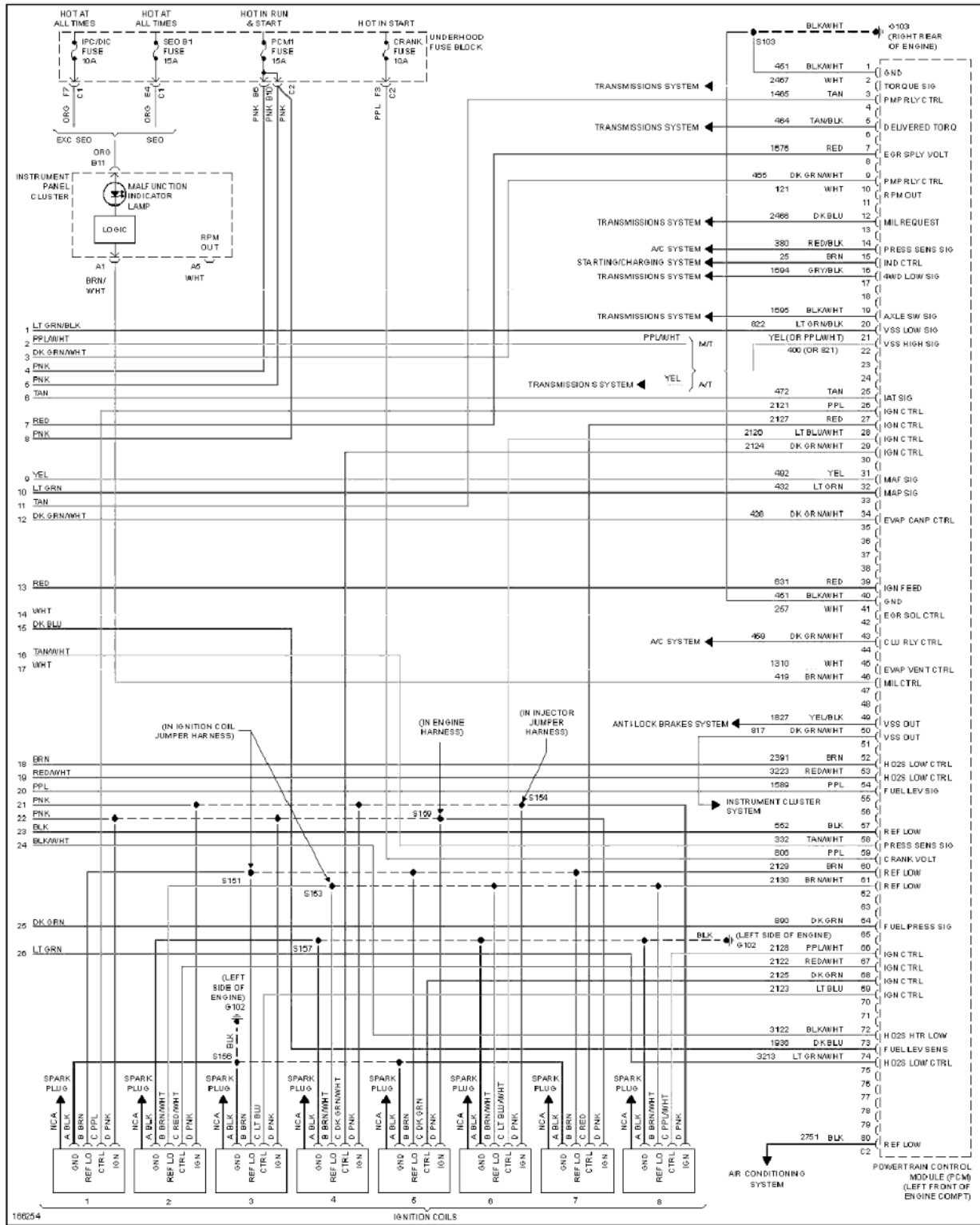
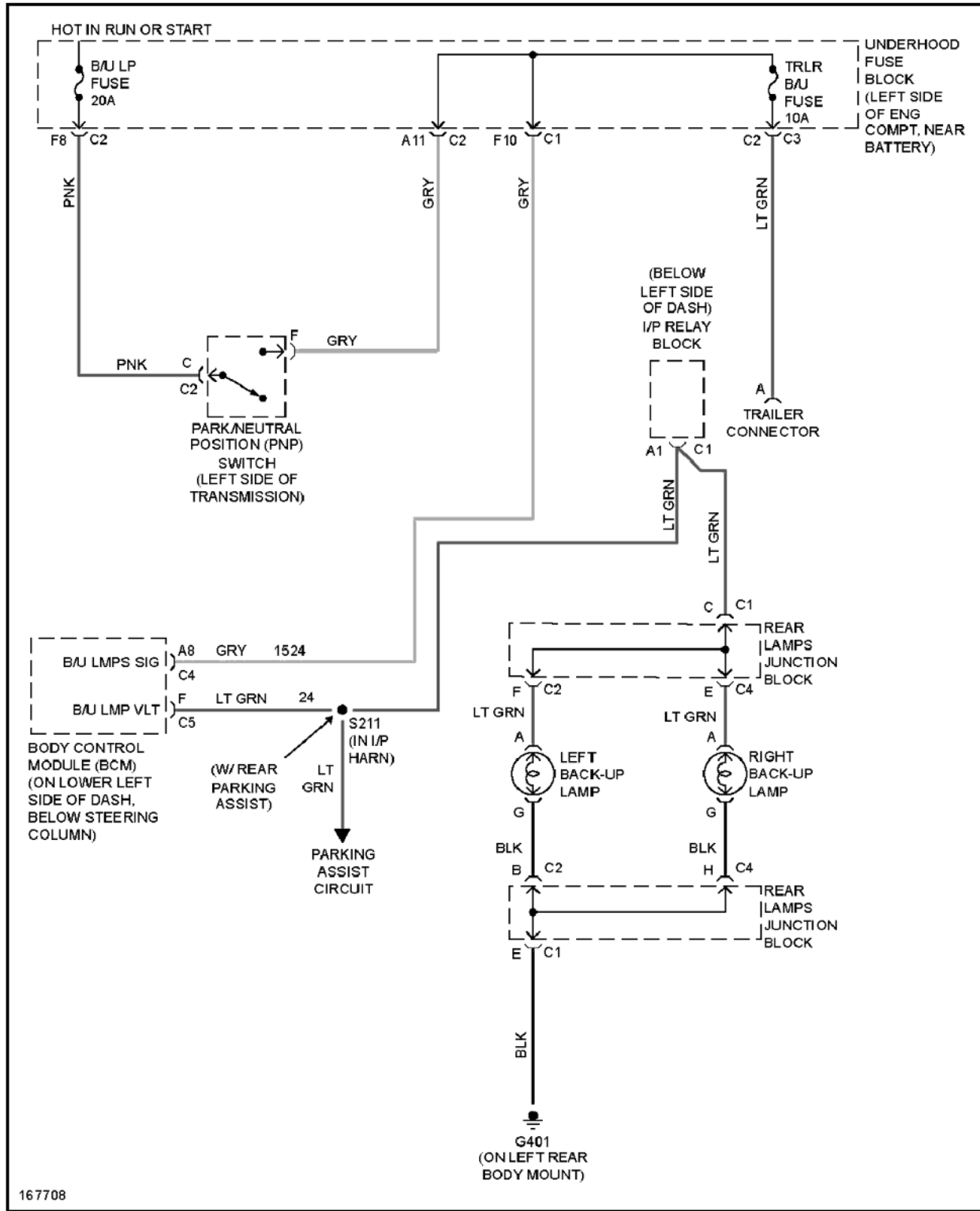

Fig. 42: 8.1L VIN G, Engine Performance Circuit (5 of 5)

### EXTERIOR LIGHTS

# 2003 Chevrolet Suburban C1500

2003 SYSTEM WIRING DIAGRAMS Chevrolet - Suburban



**Fig. 43: Back-up Lamps Circuit**

# 2003 Chevrolet Suburban C1500

## 2003 SYSTEM WIRING DIAGRAMS Chevrolet - Suburban

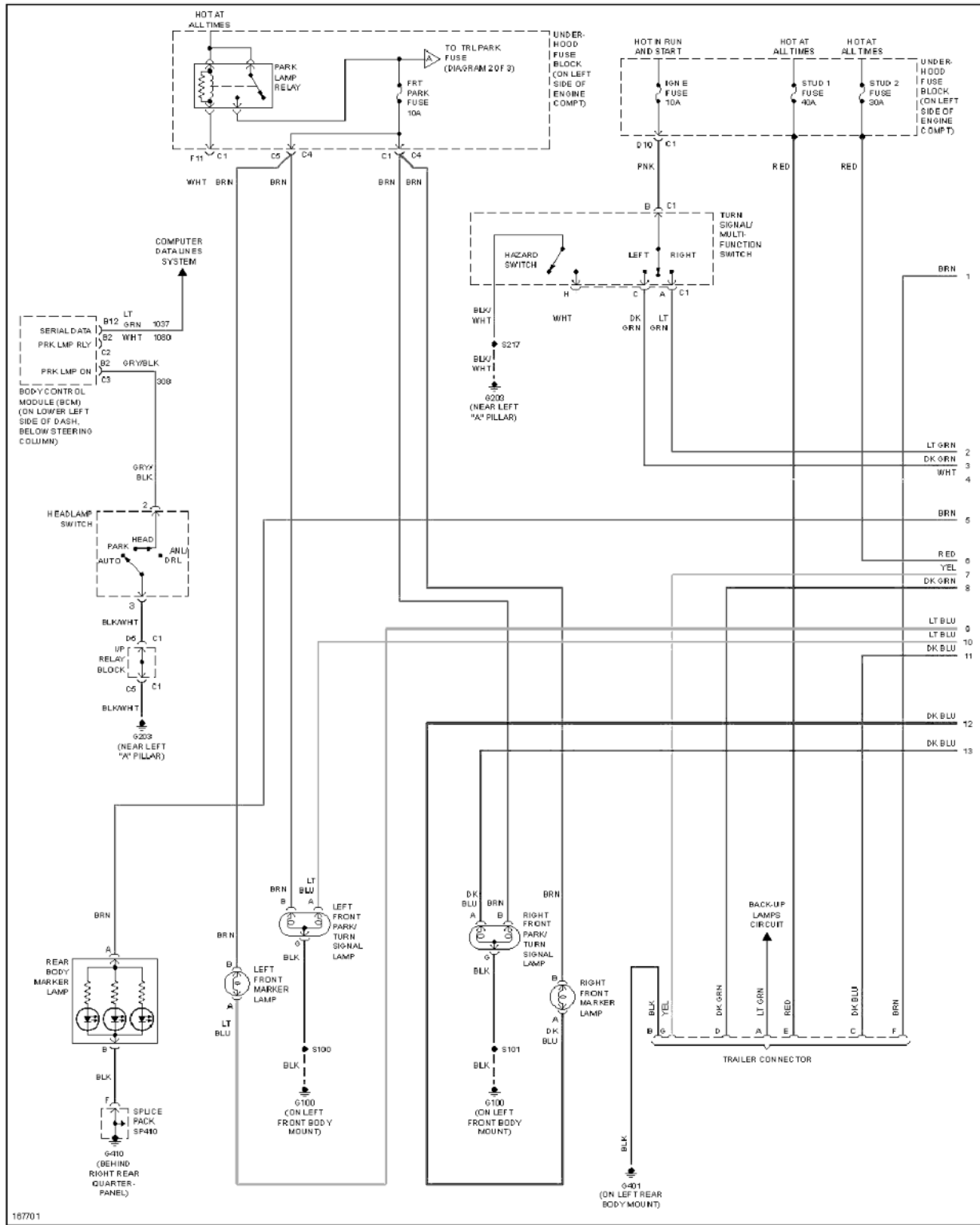

Fig. 44: Exterior Lamps Circuit (1 of 3)



# 2003 Chevrolet Suburban C1500

## 2003 SYSTEM WIRING DIAGRAMS Chevrolet - Suburban

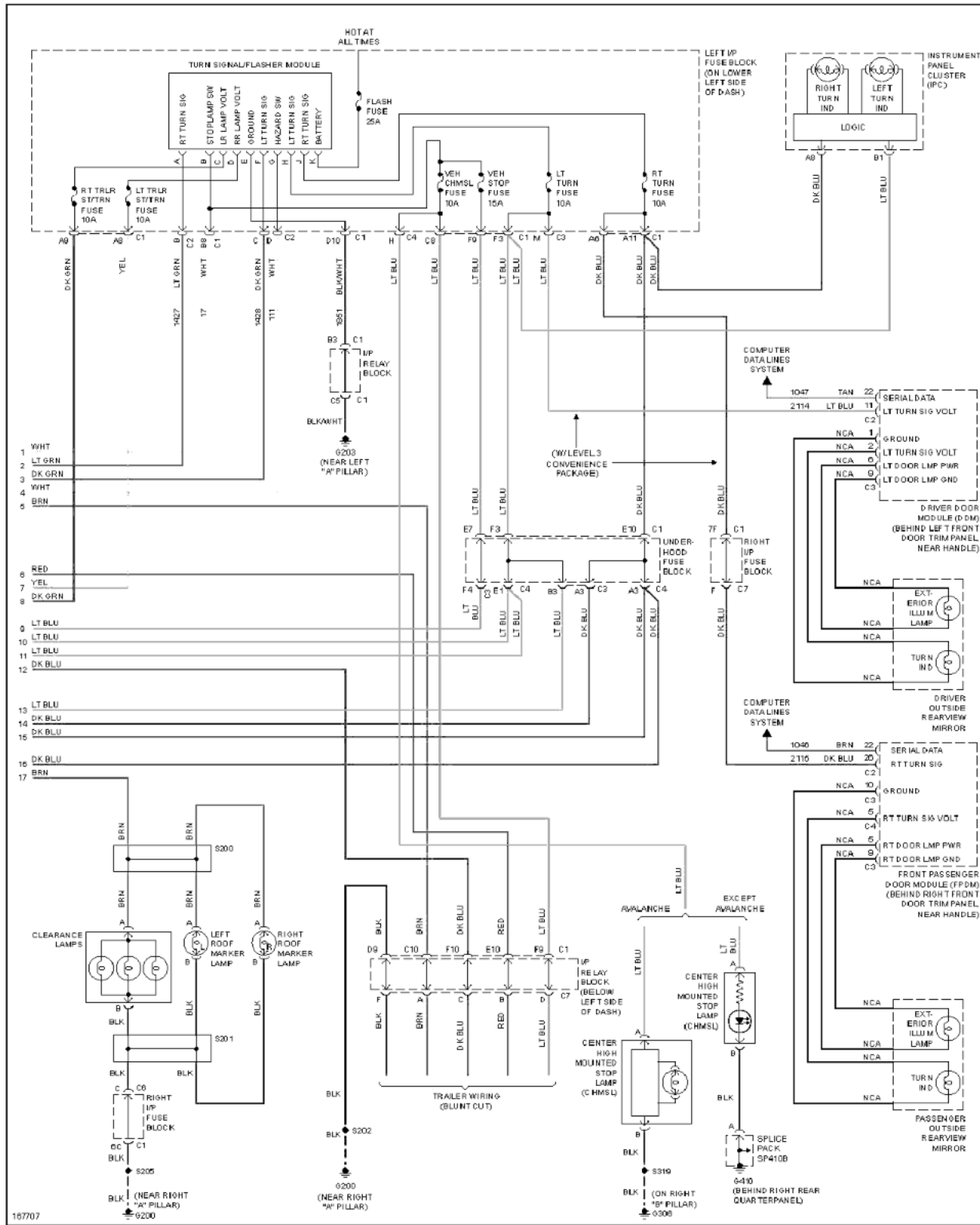

Fig. 46: Exterior Lamps Circuit (3 of 3)

### GROUND DISTRIBUTION

# 2003 Chevrolet Suburban C1500

## 2003 SYSTEM WIRING DIAGRAMS Chevrolet - Suburban

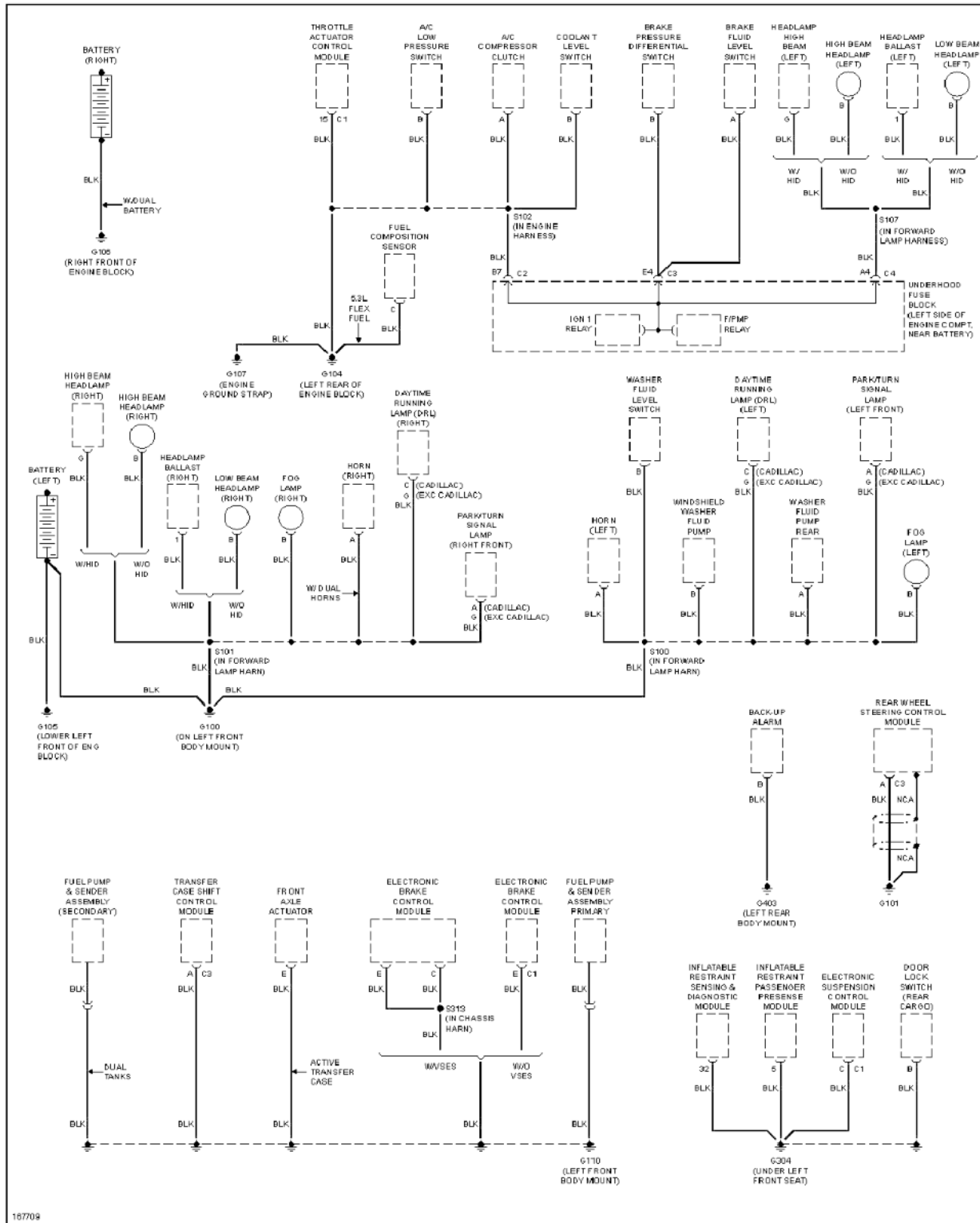

Fig. 47: Ground Distribution Circuit (1 of 5)

# 2003 Chevrolet Suburban C1500

## 2003 SYSTEM WIRING DIAGRAMS Chevrolet - Suburban

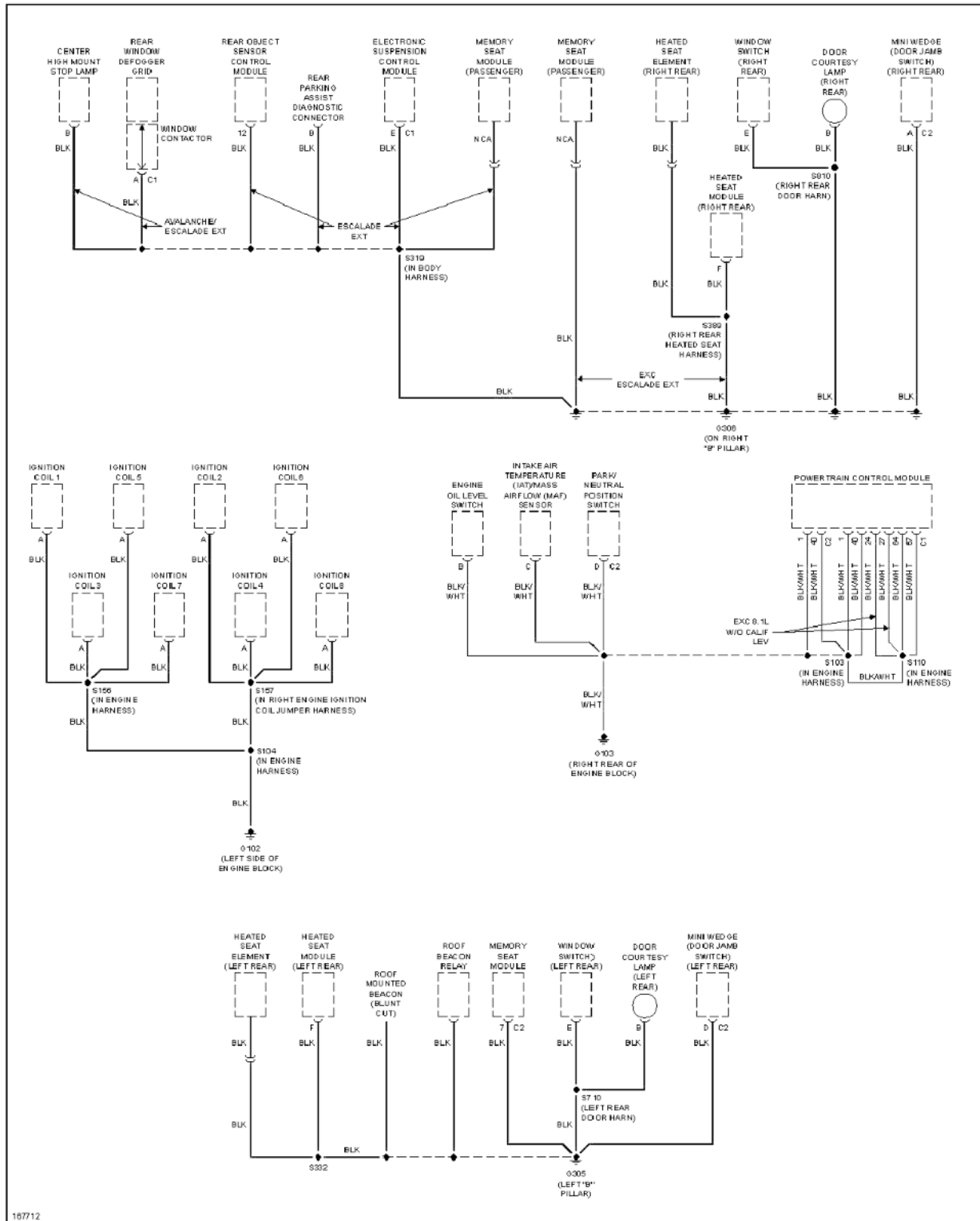

Fig. 48: Ground Distribution Circuit (2 of 5)



# 2003 Chevrolet Suburban C1500

## 2003 SYSTEM WIRING DIAGRAMS Chevrolet - Suburban

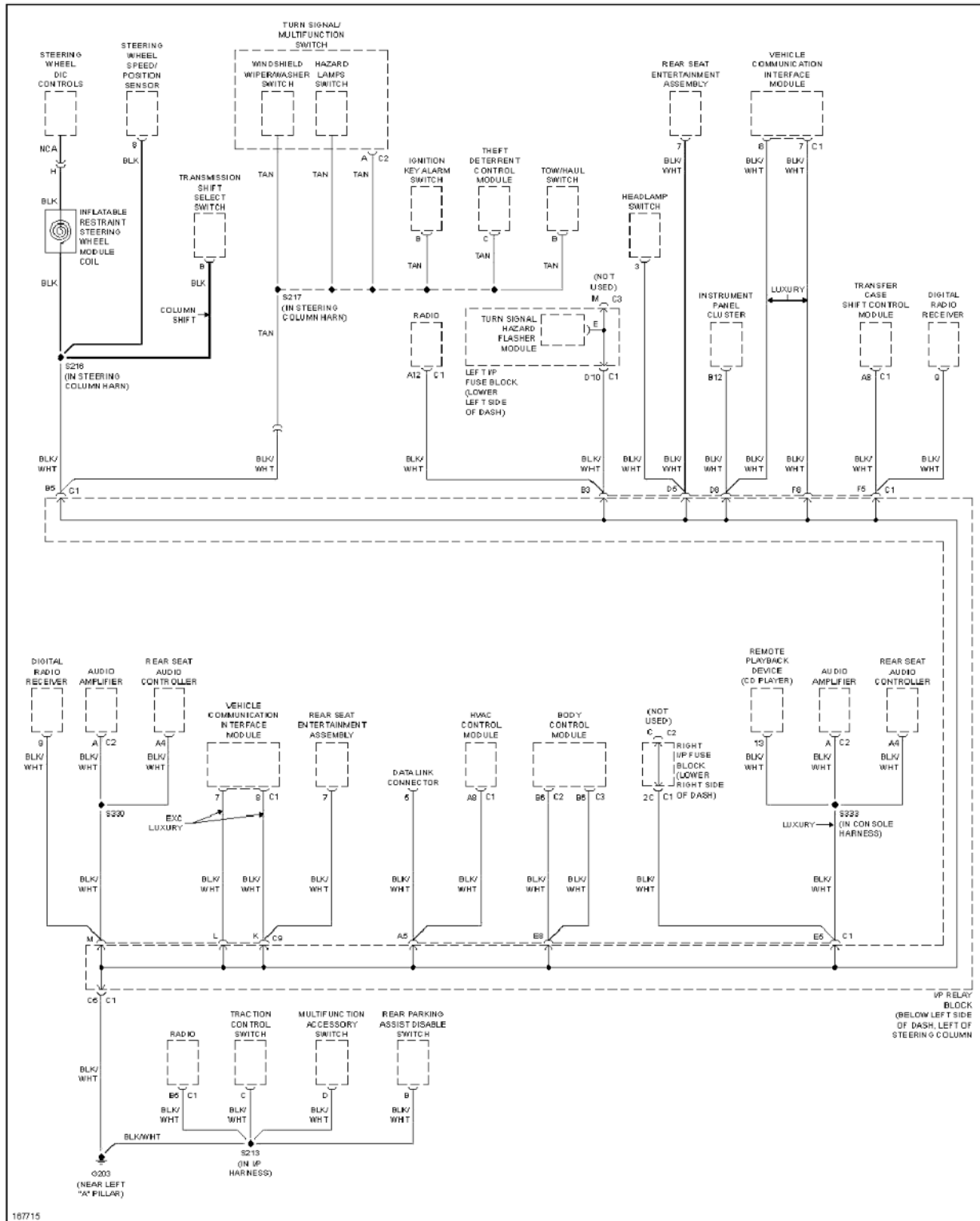

Fig. 50: Ground Distribution Circuit (4 of 5)

# 2003 Chevrolet Suburban C1500

## 2003 SYSTEM WIRING DIAGRAMS Chevrolet - Suburban

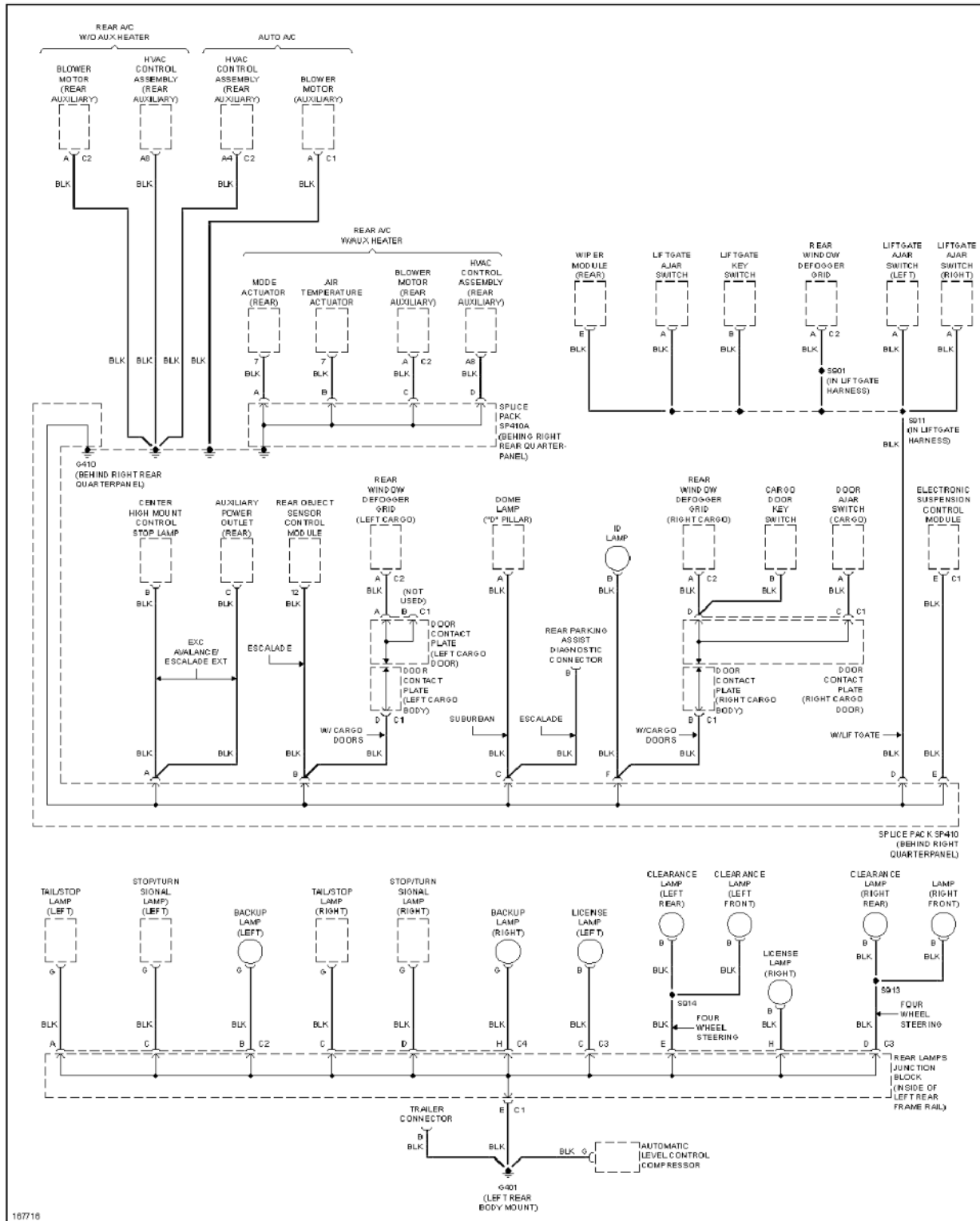

Fig. 51: Ground Distribution Circuit (5 of 5)

### HEADLIGHTS

# 2003 Chevrolet Suburban C1500

## 2003 SYSTEM WIRING DIAGRAMS Chevrolet - Suburban

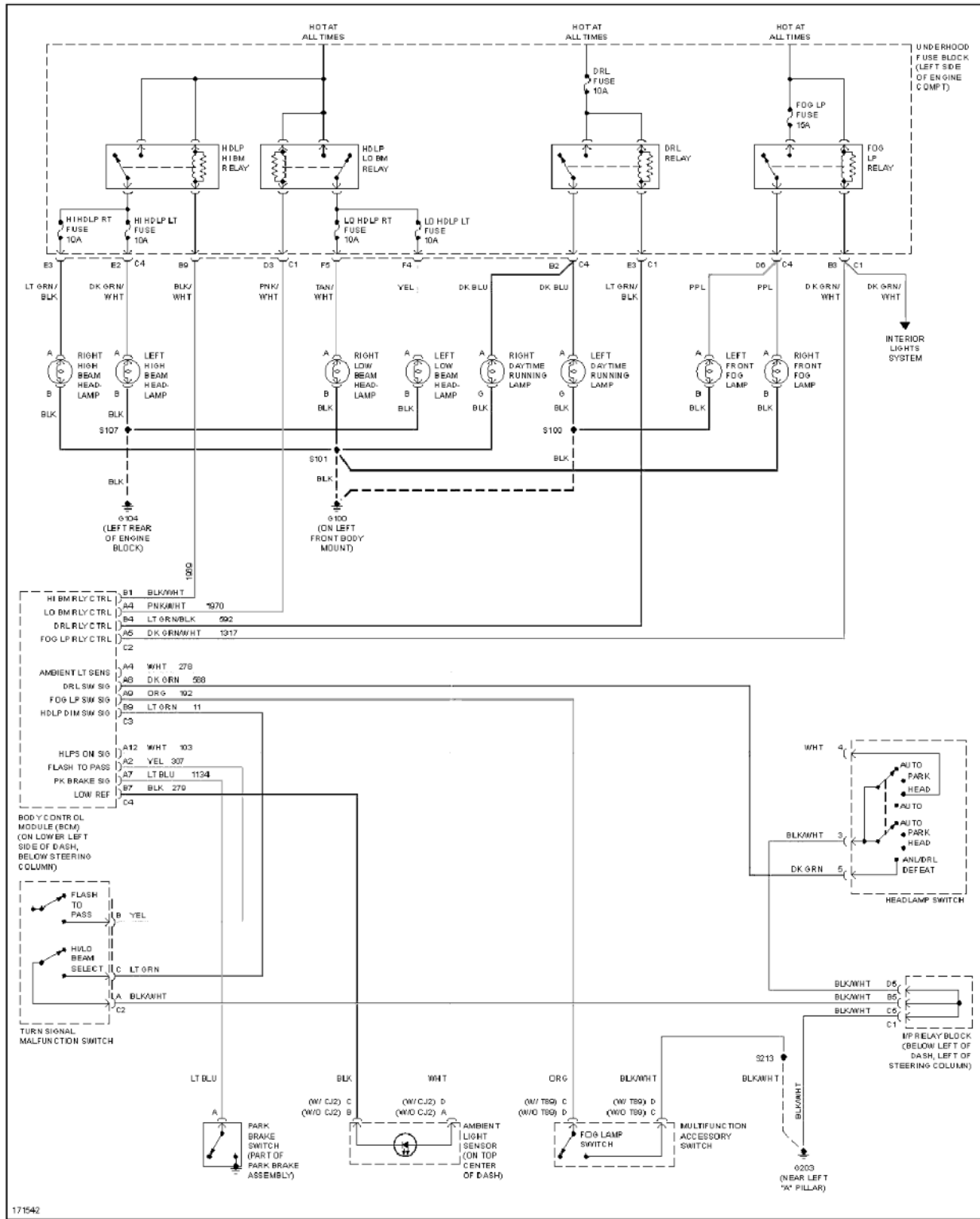

Fig. 52: Headlights Circuit

### HORN

# 2003 Chevrolet Suburban C1500

2003 SYSTEM WIRING DIAGRAMS Chevrolet - Suburban

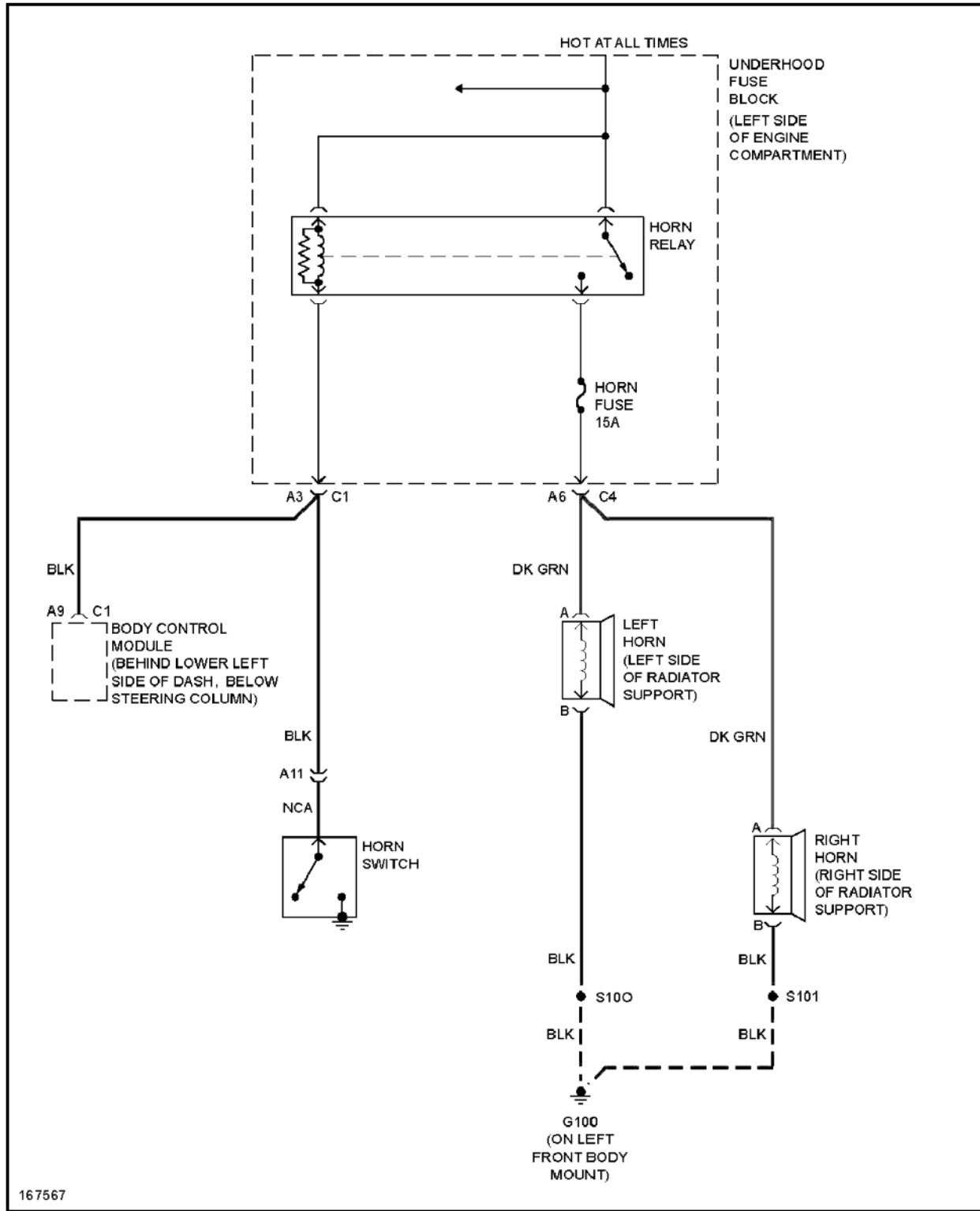

Fig. 53: Horn Circuit

## INSTRUMENT CLUSTER

# 2003 Chevrolet Suburban C1500

## 2003 SYSTEM WIRING DIAGRAMS Chevrolet - Suburban

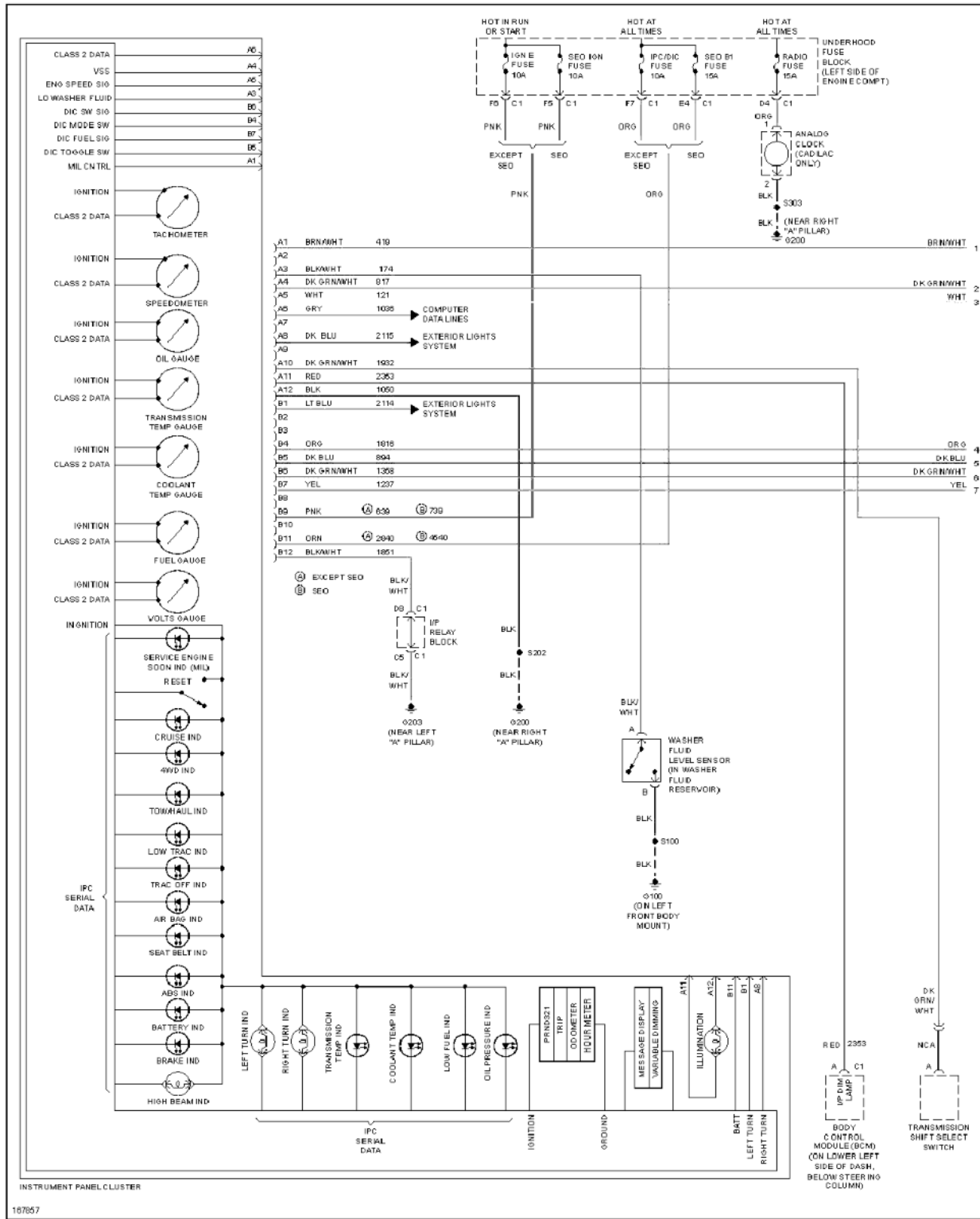

Fig. 54: Instrument Cluster Circuit (1 of 2)

# 2003 Chevrolet Suburban C1500

2003 SYSTEM WIRING DIAGRAMS Chevrolet - Suburban

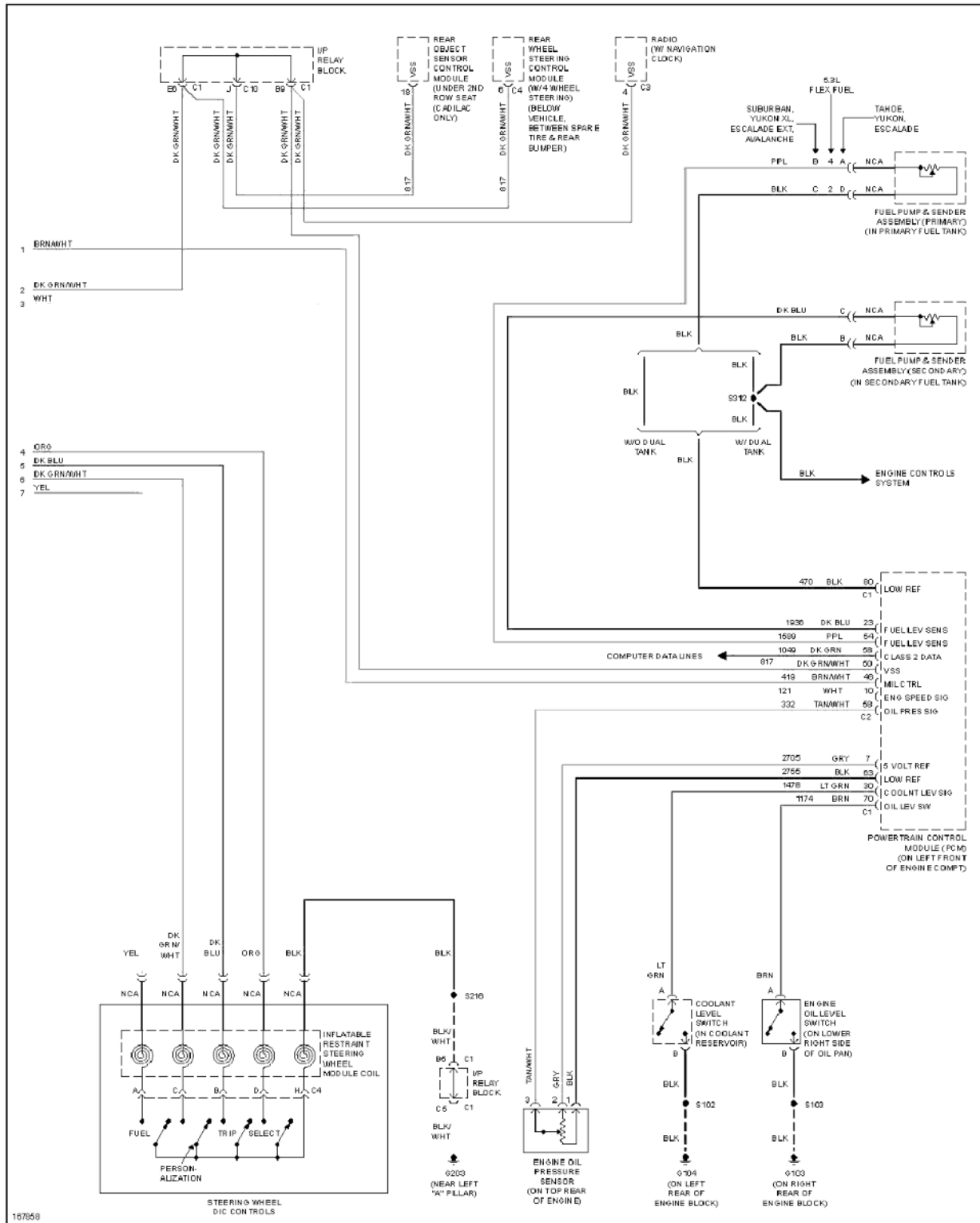

Fig. 55: Instrument Cluster Circuit (2 of 2)

## INTERIOR LIGHTS

# 2003 Chevrolet Suburban C1500

## 2003 SYSTEM WIRING DIAGRAMS Chevrolet - Suburban

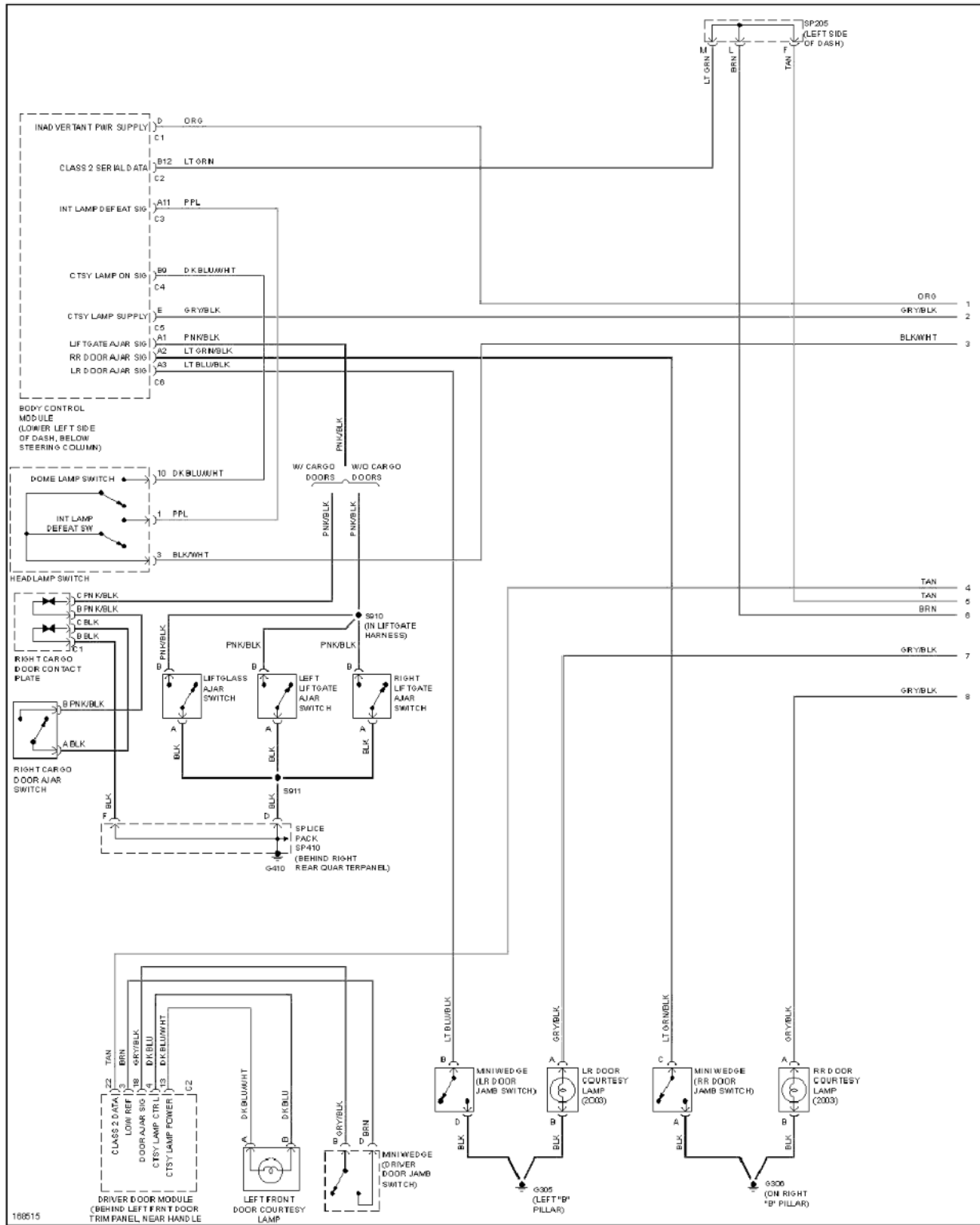
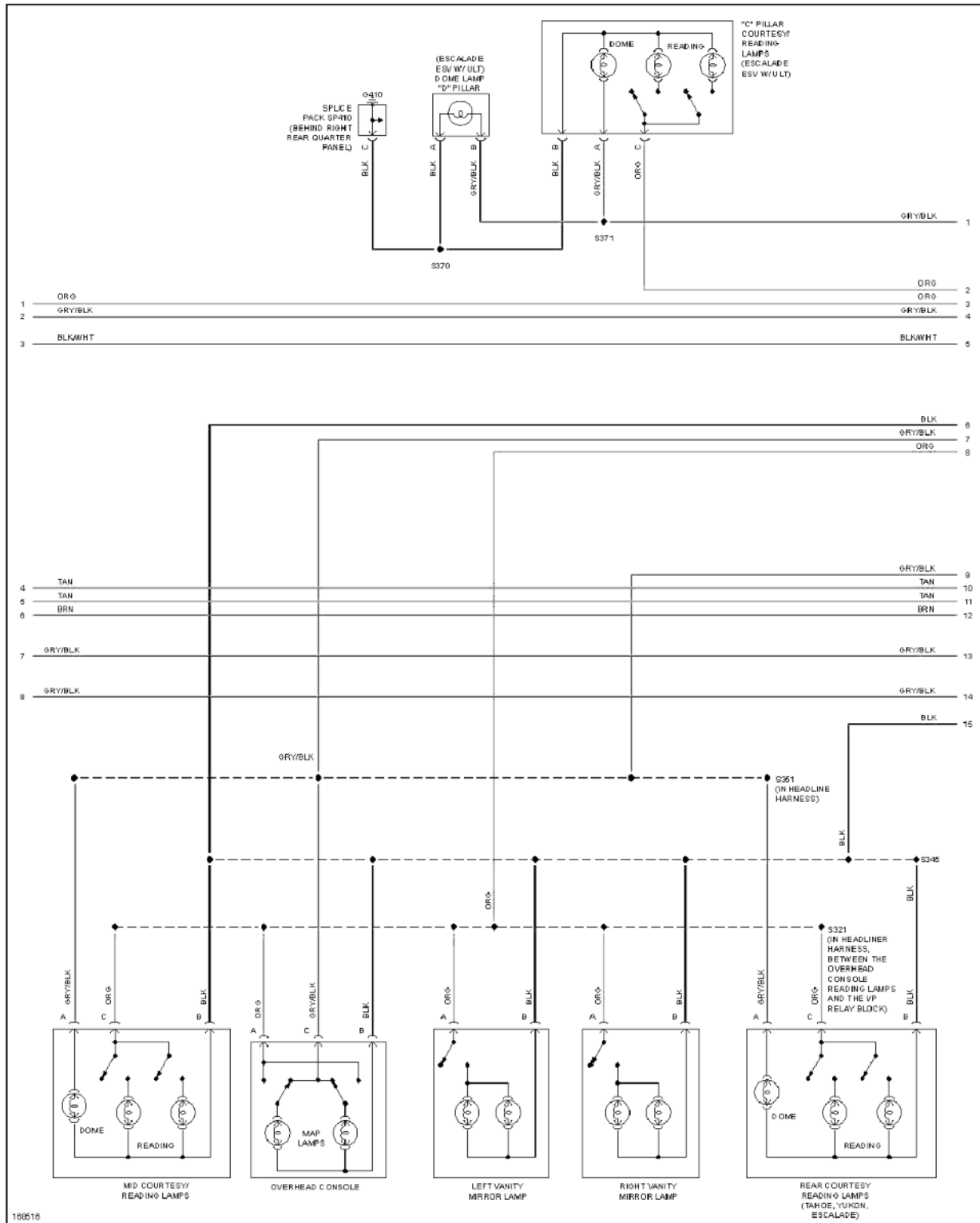

Fig. 56: Courtesy Lamps Circuit (1 of 3)

# 2003 Chevrolet Suburban C1500

## 2003 SYSTEM WIRING DIAGRAMS Chevrolet - Suburban



**Fig. 57: Courtesy Lamps Circuit (2 of 3)**

# 2003 Chevrolet Suburban C1500

2003 SYSTEM WIRING DIAGRAMS Chevrolet - Suburban

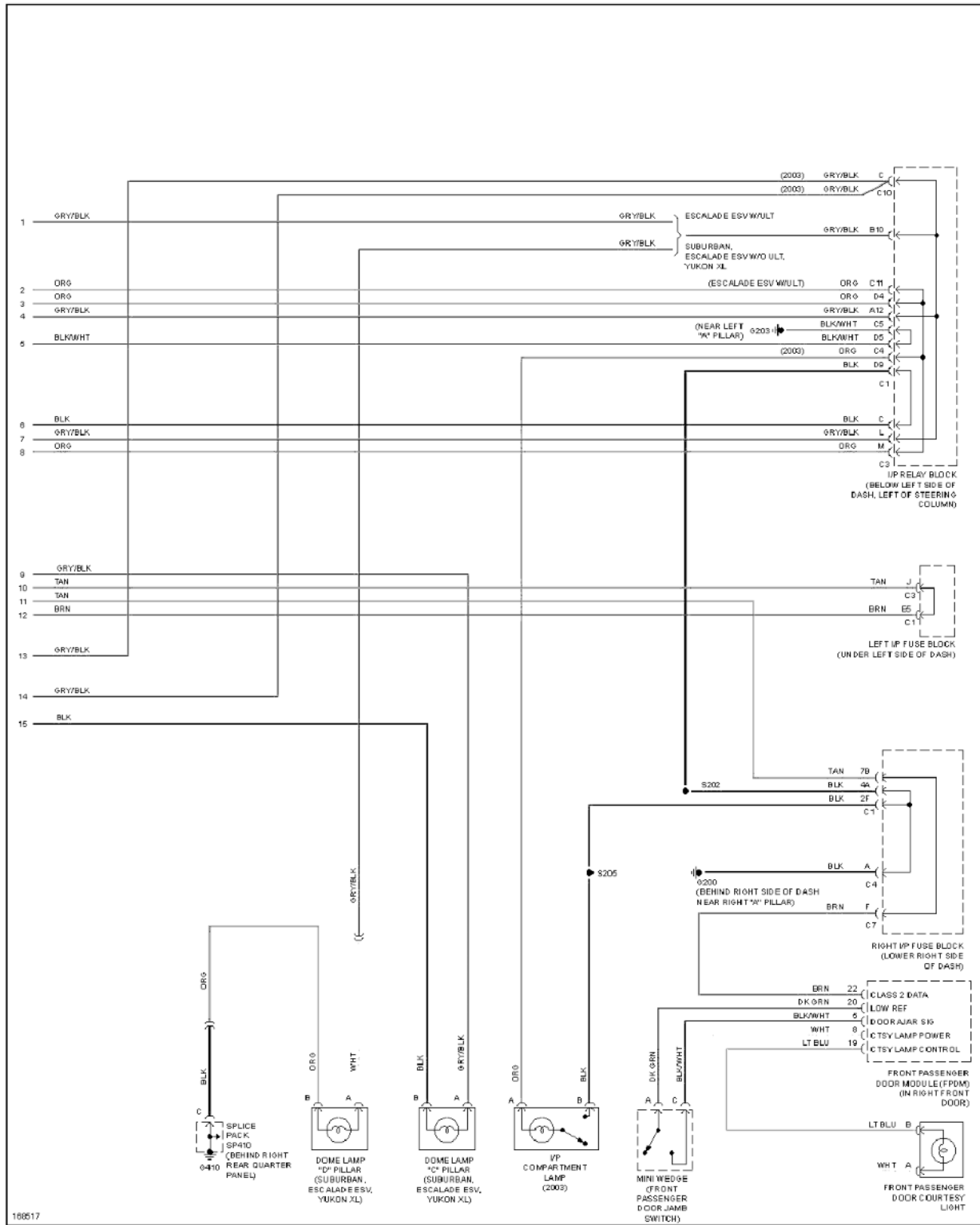

**Fig. 58: Courtesy Lamps Circuit (3 of 3)**

# 2003 Chevrolet Suburban C1500

## 2003 SYSTEM WIRING DIAGRAMS Chevrolet - Suburban

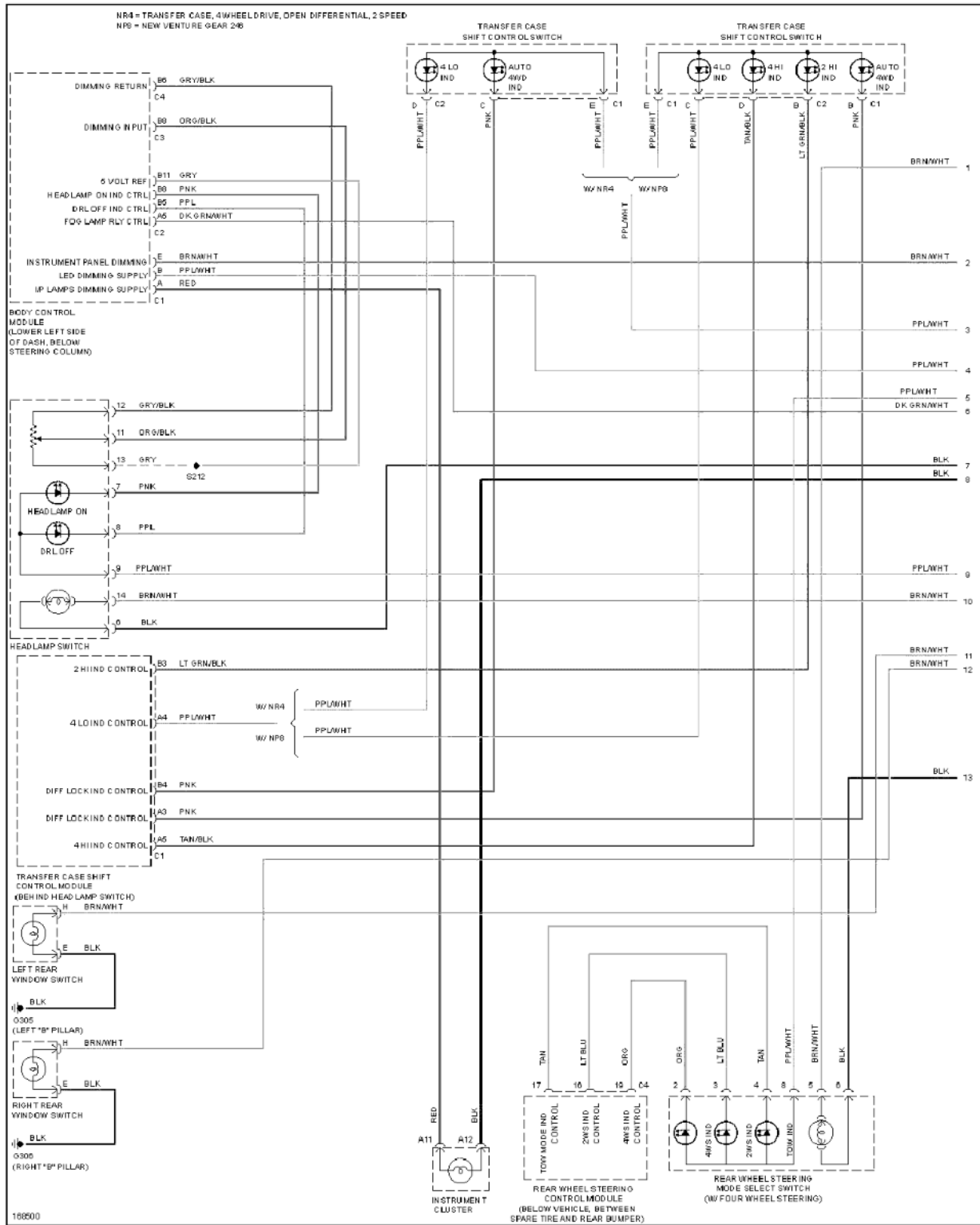

**Fig. 59: Instrument Illumination Circuit (1 of 3)**

# 2003 Chevrolet Suburban C1500

## 2003 SYSTEM WIRING DIAGRAMS Chevrolet - Suburban

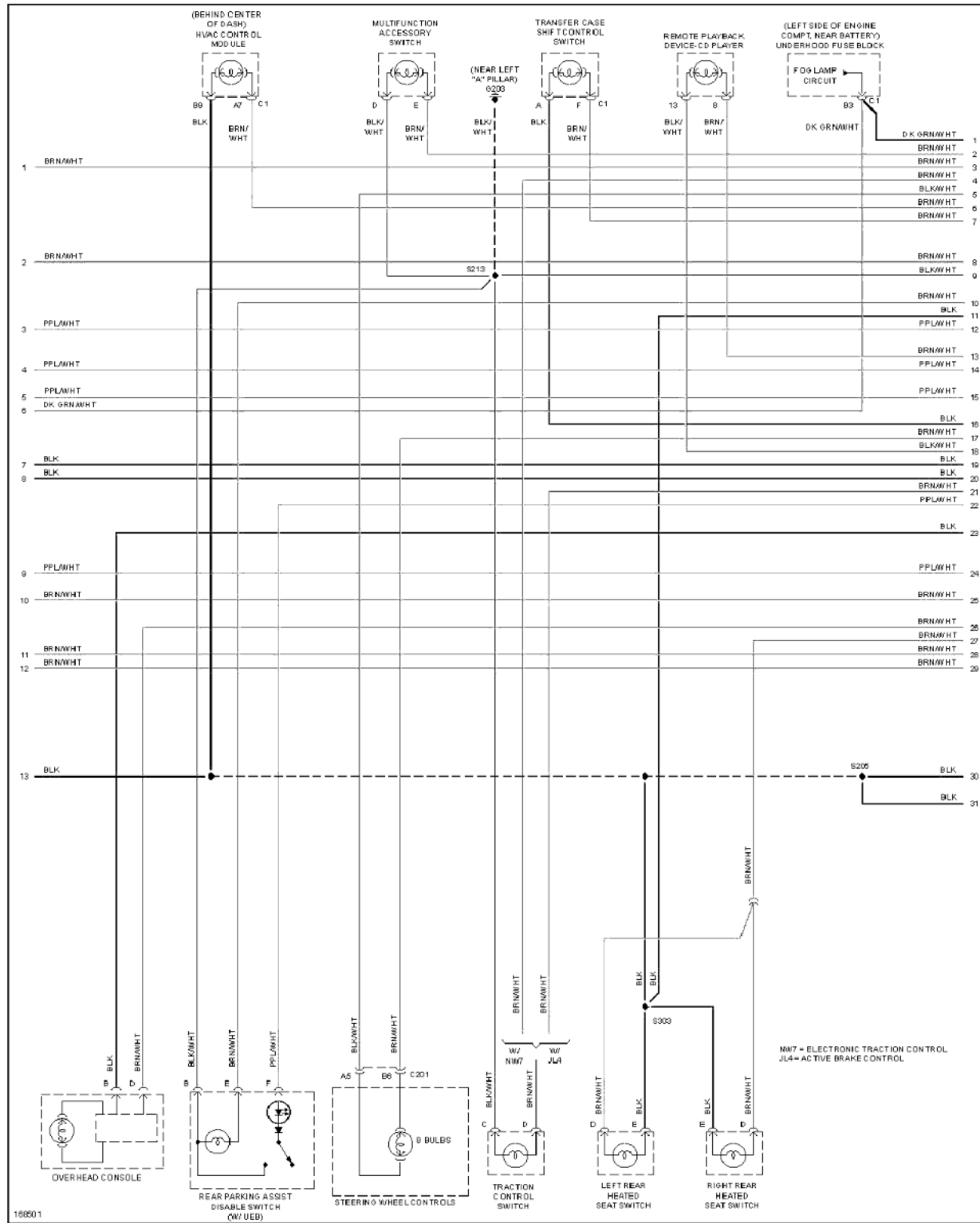

**Fig. 60: Instrument Illumination Circuit (2 of 3)**

# 2003 Chevrolet Suburban C1500

## 2003 SYSTEM WIRING DIAGRAMS Chevrolet - Suburban

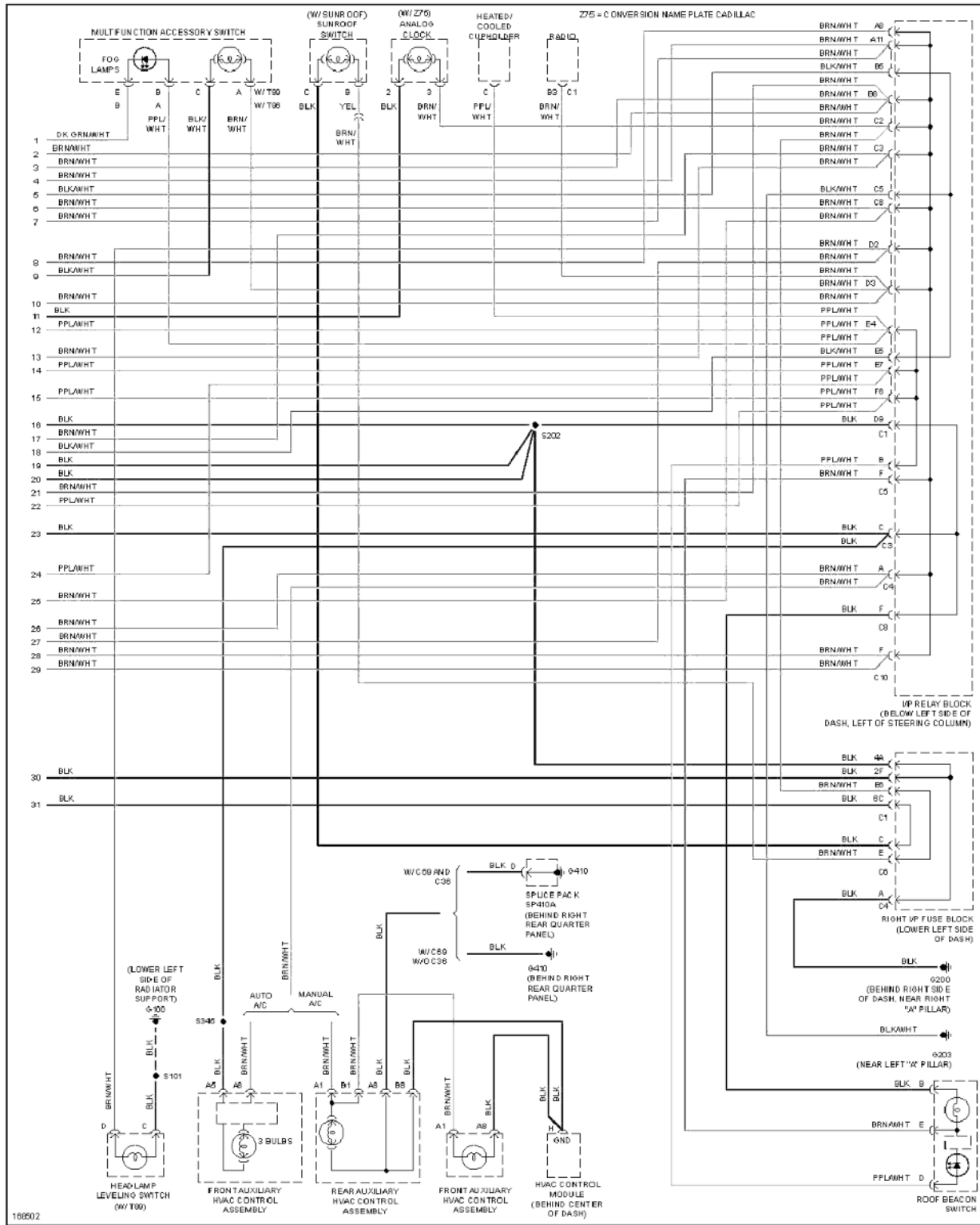
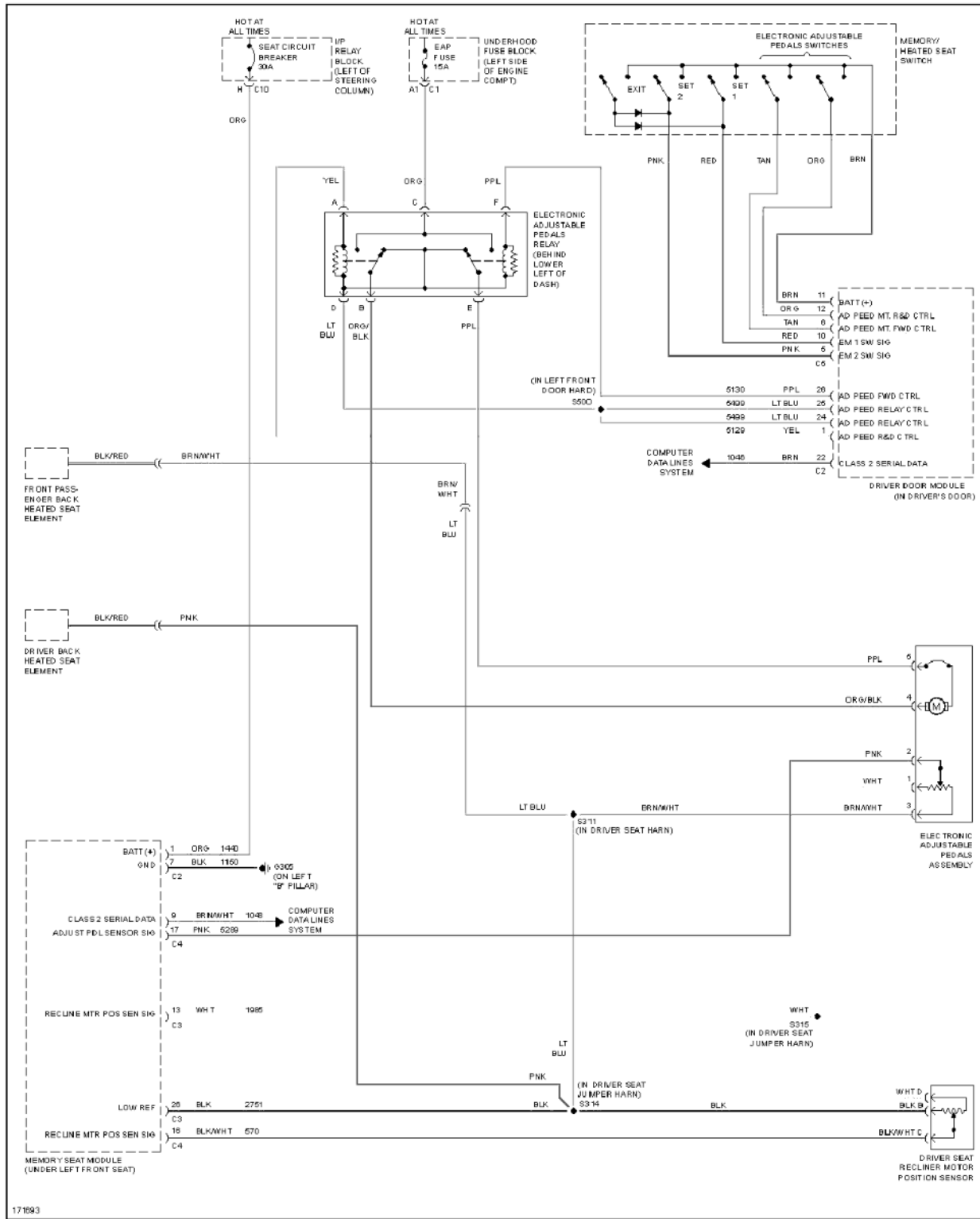

Fig. 61: Instrument Illumination Circuit (3 of 3)

### MEMORY SYSTEMS

# 2003 Chevrolet Suburban C1500

## 2003 SYSTEM WIRING DIAGRAMS Chevrolet - Suburban



**Fig. 62: Adjustable Pedal Circuit**

# 2003 Chevrolet Suburban C1500

## 2003 SYSTEM WIRING DIAGRAMS Chevrolet - Suburban

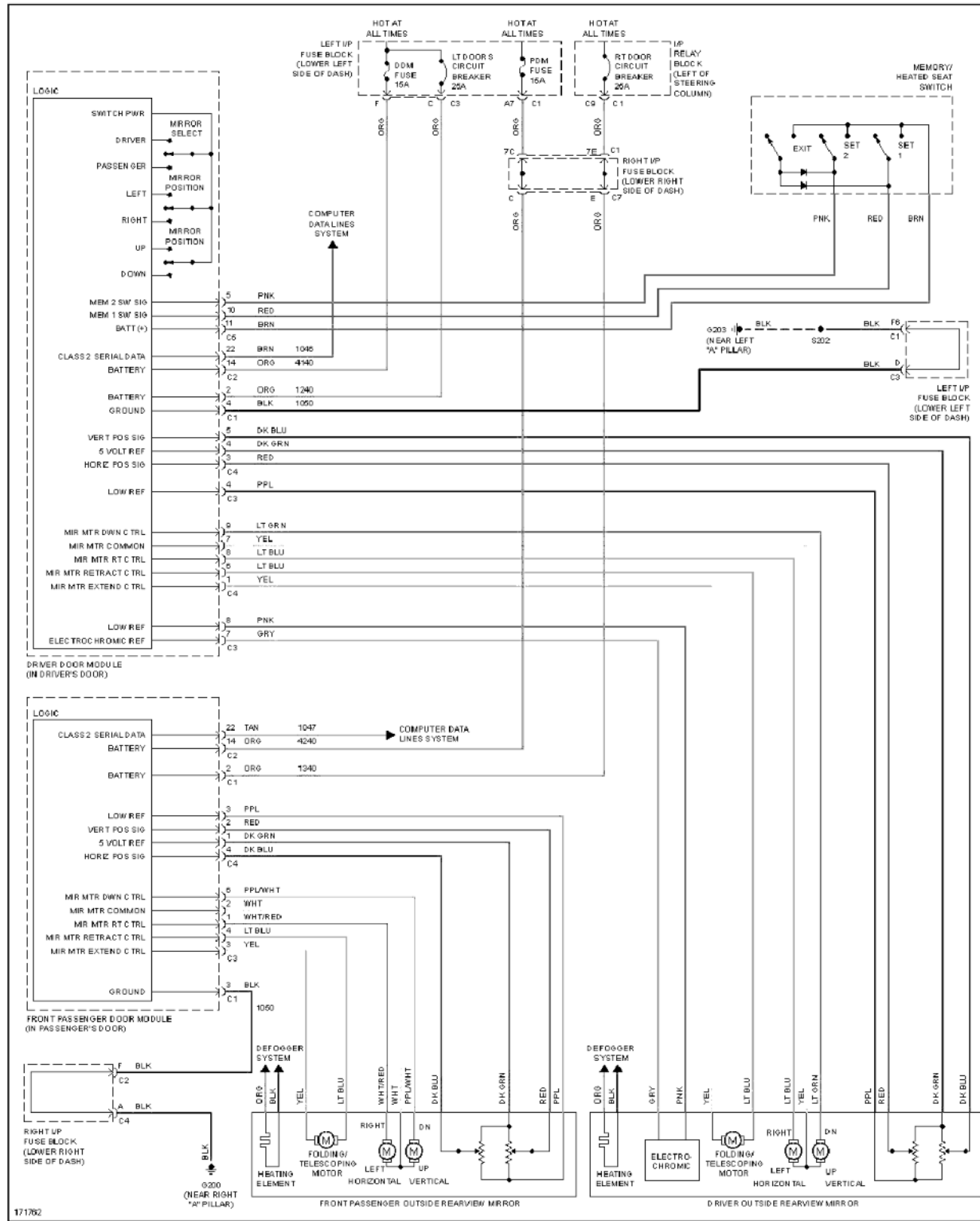

**Fig. 63: Memory Mirrors Circuit**



# 2003 Chevrolet Suburban C1500

## 2003 SYSTEM WIRING DIAGRAMS Chevrolet - Suburban

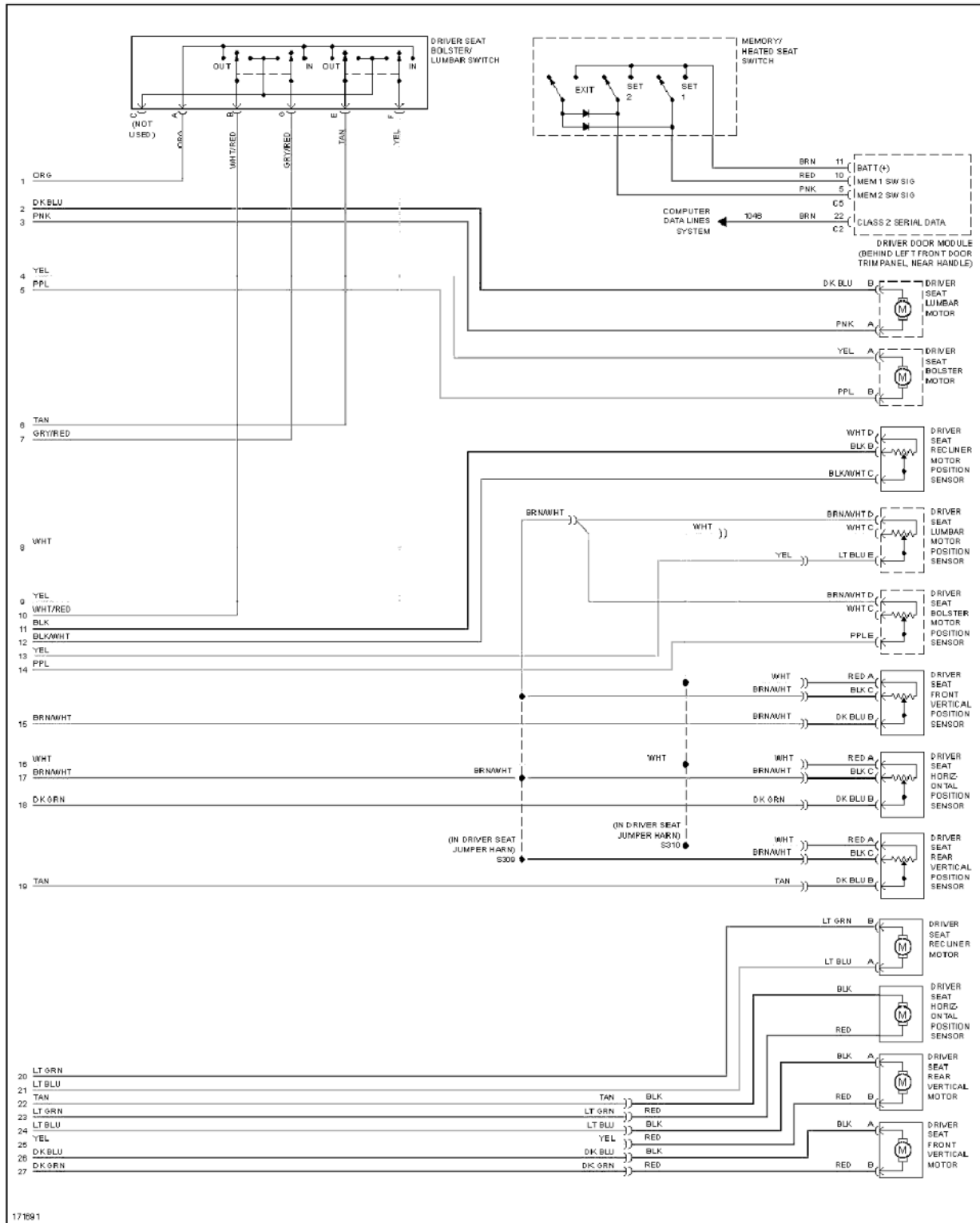

Fig. 65: Memory Seat Circuit (2 of 2)

### POWER DISTRIBUTION

# 2003 Chevrolet Suburban C1500

## 2003 SYSTEM WIRING DIAGRAMS Chevrolet - Suburban

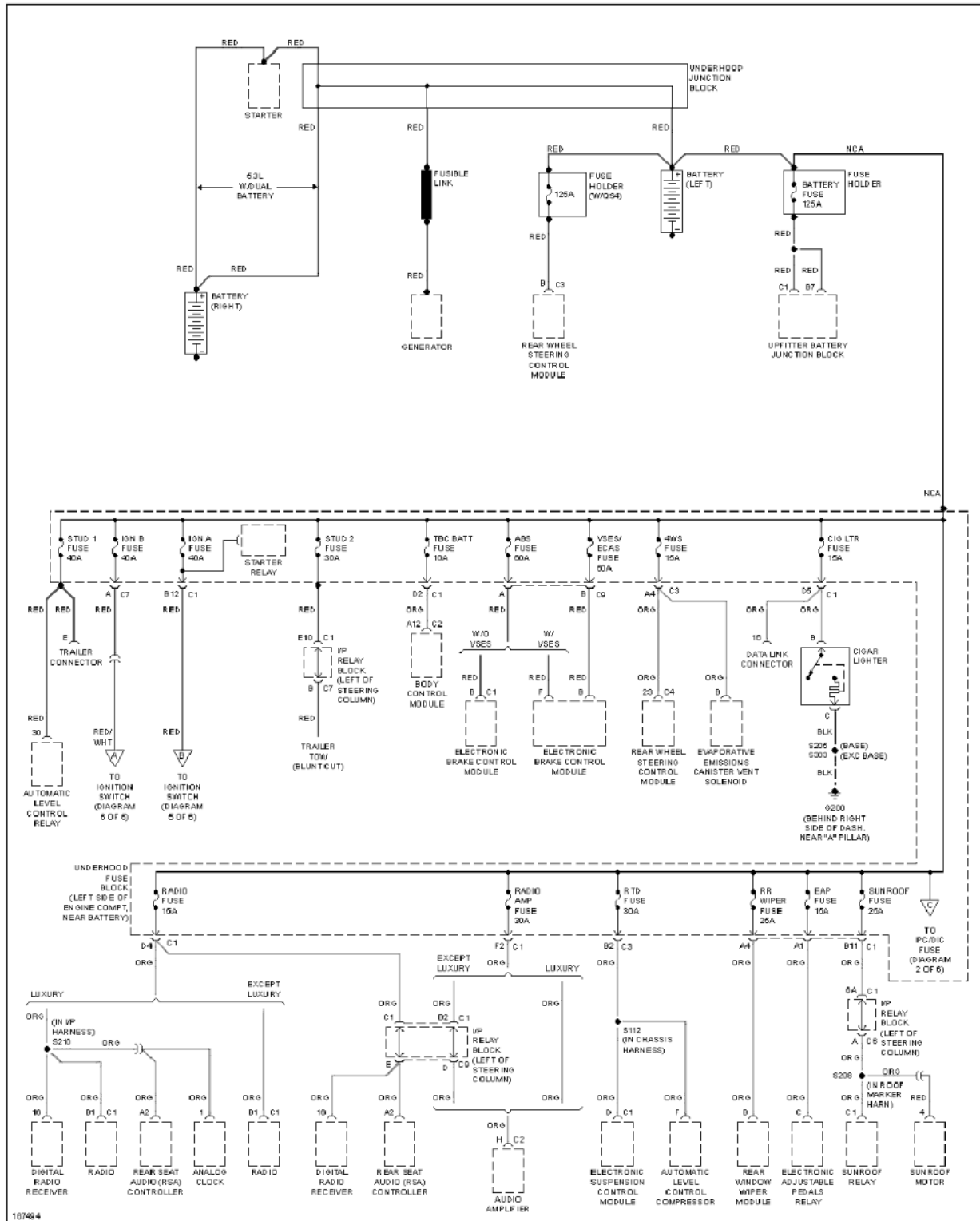

Fig. 66: Power Distribution Circuit (1 of 6)

# 2003 Chevrolet Suburban C1500

## 2003 SYSTEM WIRING DIAGRAMS Chevrolet - Suburban

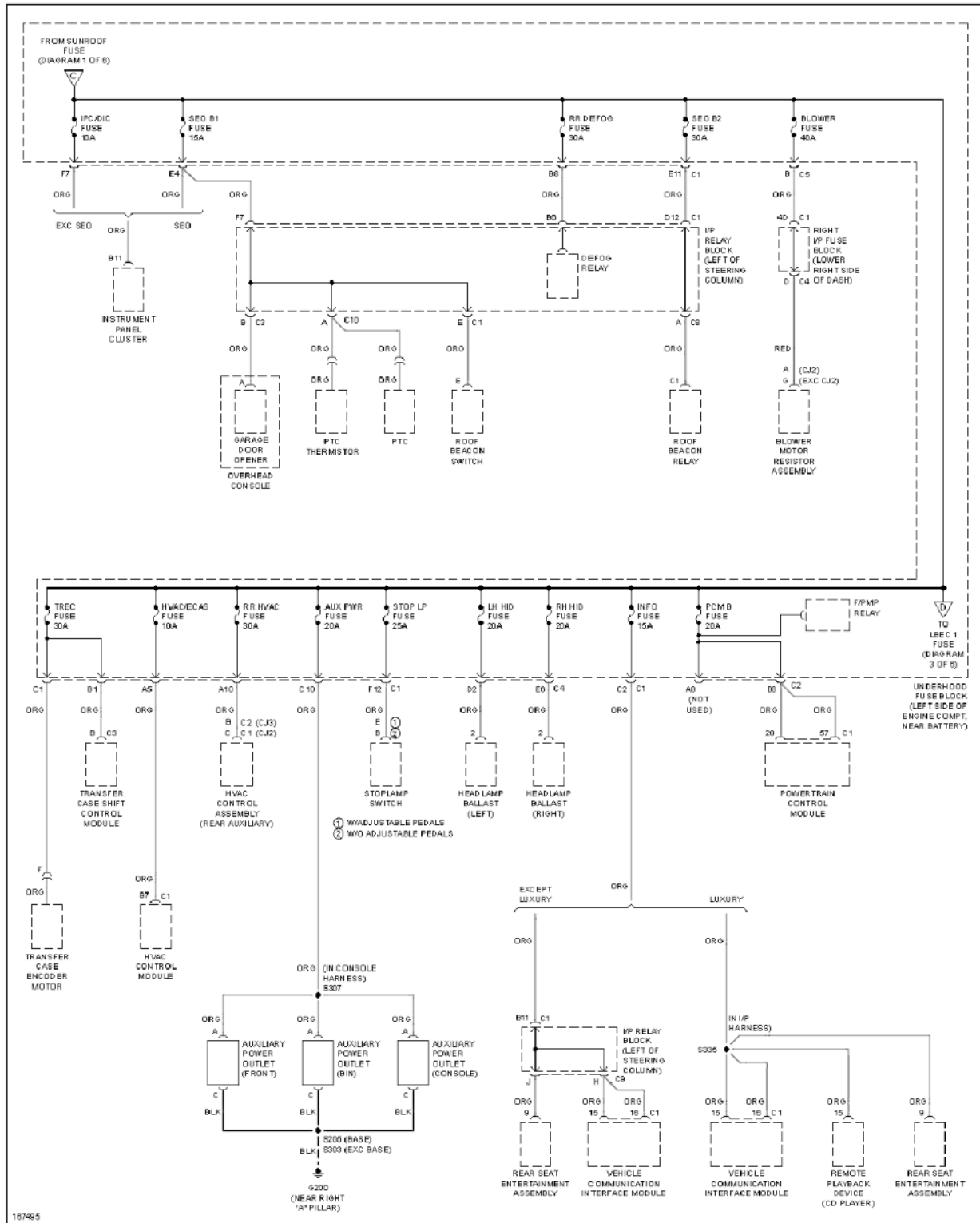

Fig. 67: Power Distribution Circuit (2 of 6)

# 2003 Chevrolet Suburban C1500

## 2003 SYSTEM WIRING DIAGRAMS Chevrolet - Suburban

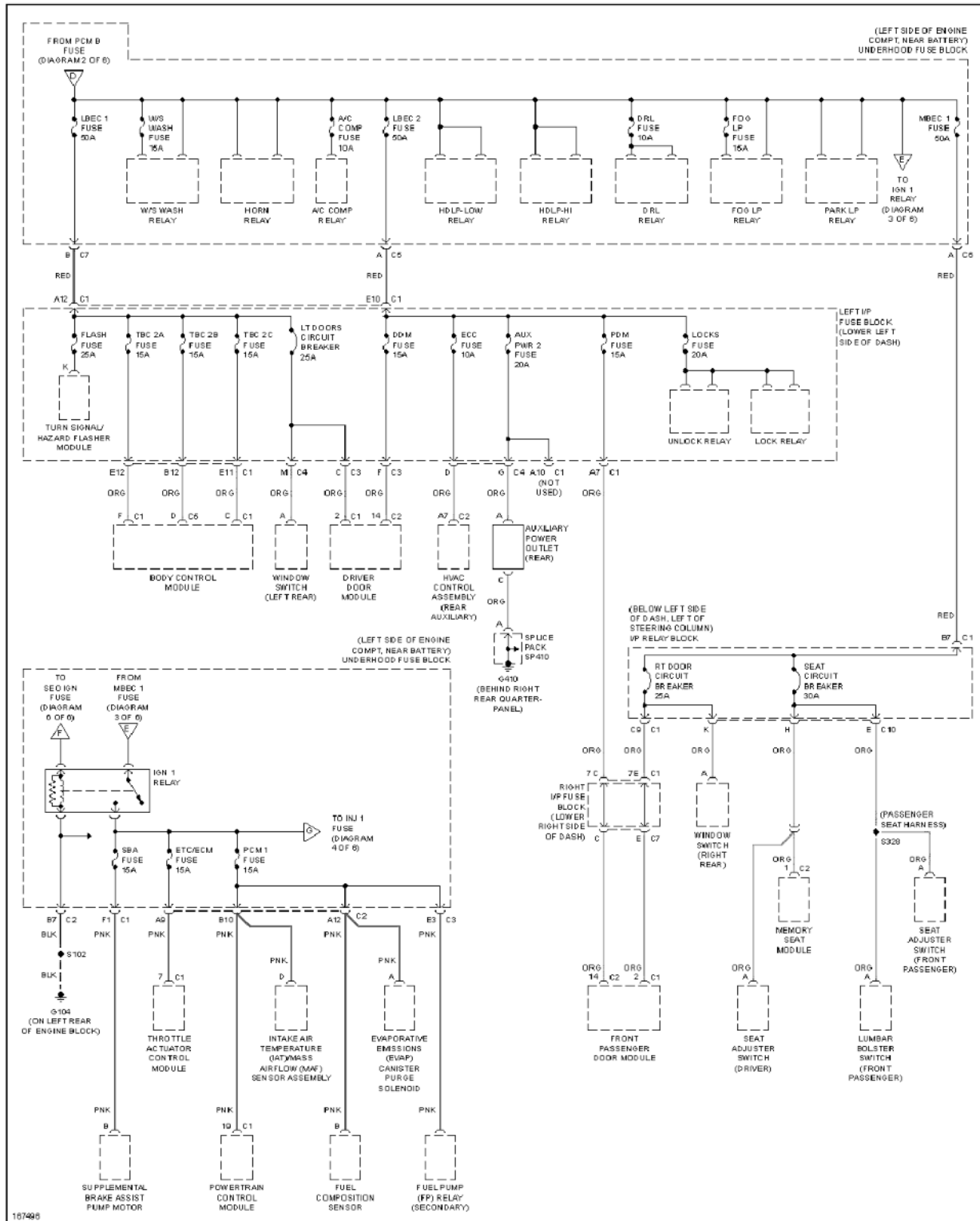

Fig. 68: Power Distribution Circuit (3 of 6)

# 2003 Chevrolet Suburban C1500

## 2003 SYSTEM WIRING DIAGRAMS Chevrolet - Suburban

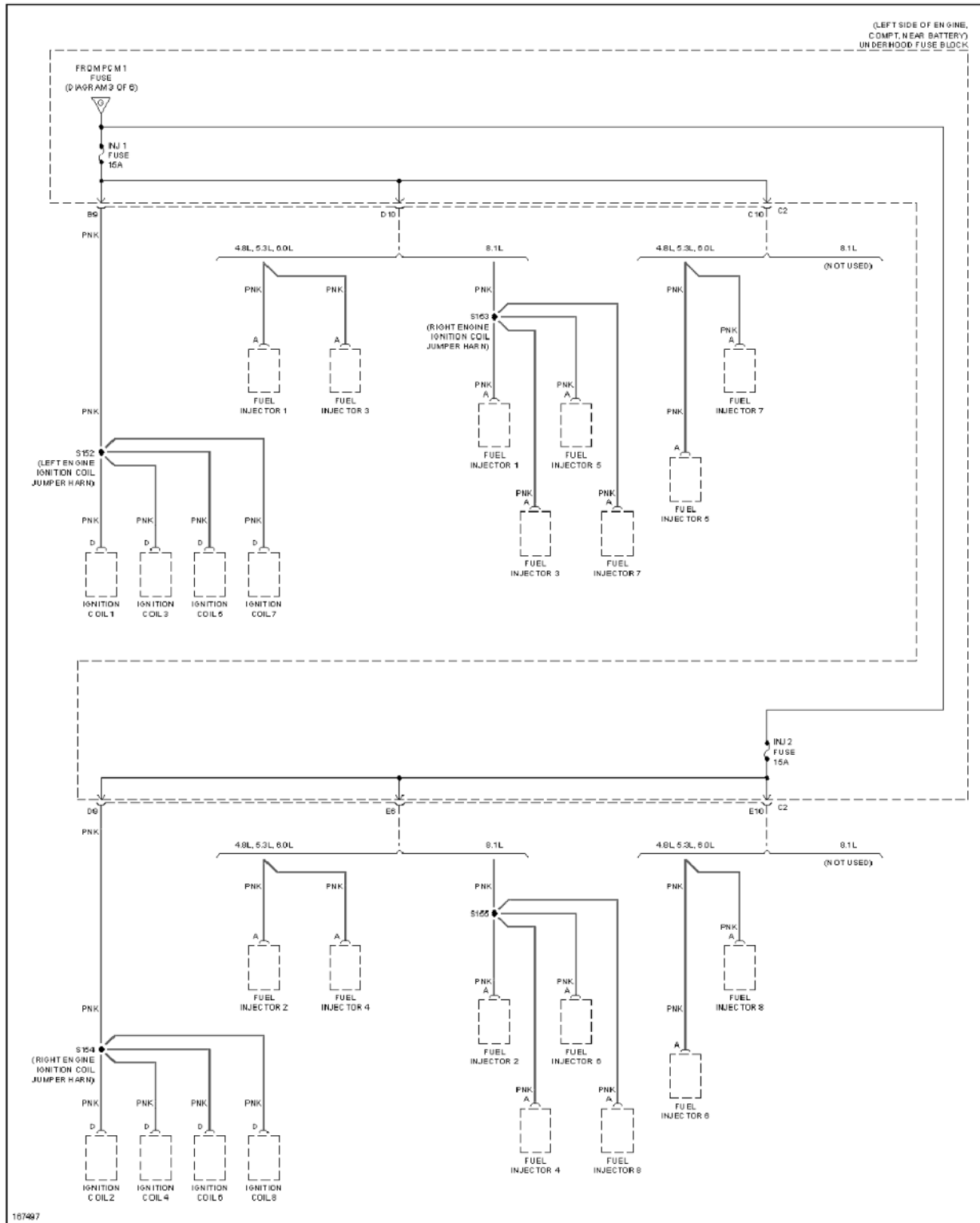

Fig. 69: Power Distribution Circuit (4 of 6)

# 2003 Chevrolet Suburban C1500

## 2003 SYSTEM WIRING DIAGRAMS Chevrolet - Suburban

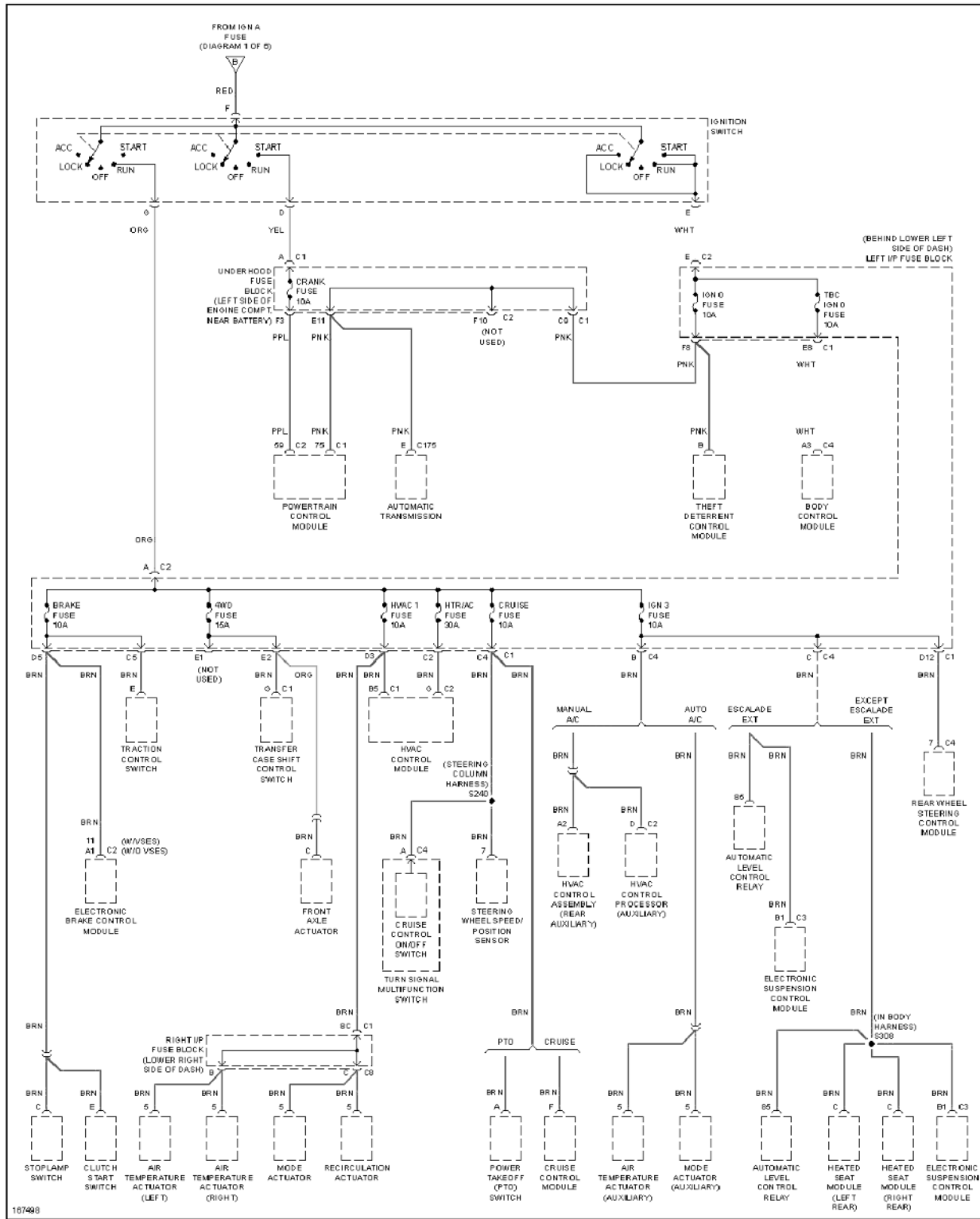

Fig. 70: Power Distribution Circuit (5 of 6)

# 2003 Chevrolet Suburban C1500

## 2003 SYSTEM WIRING DIAGRAMS Chevrolet - Suburban

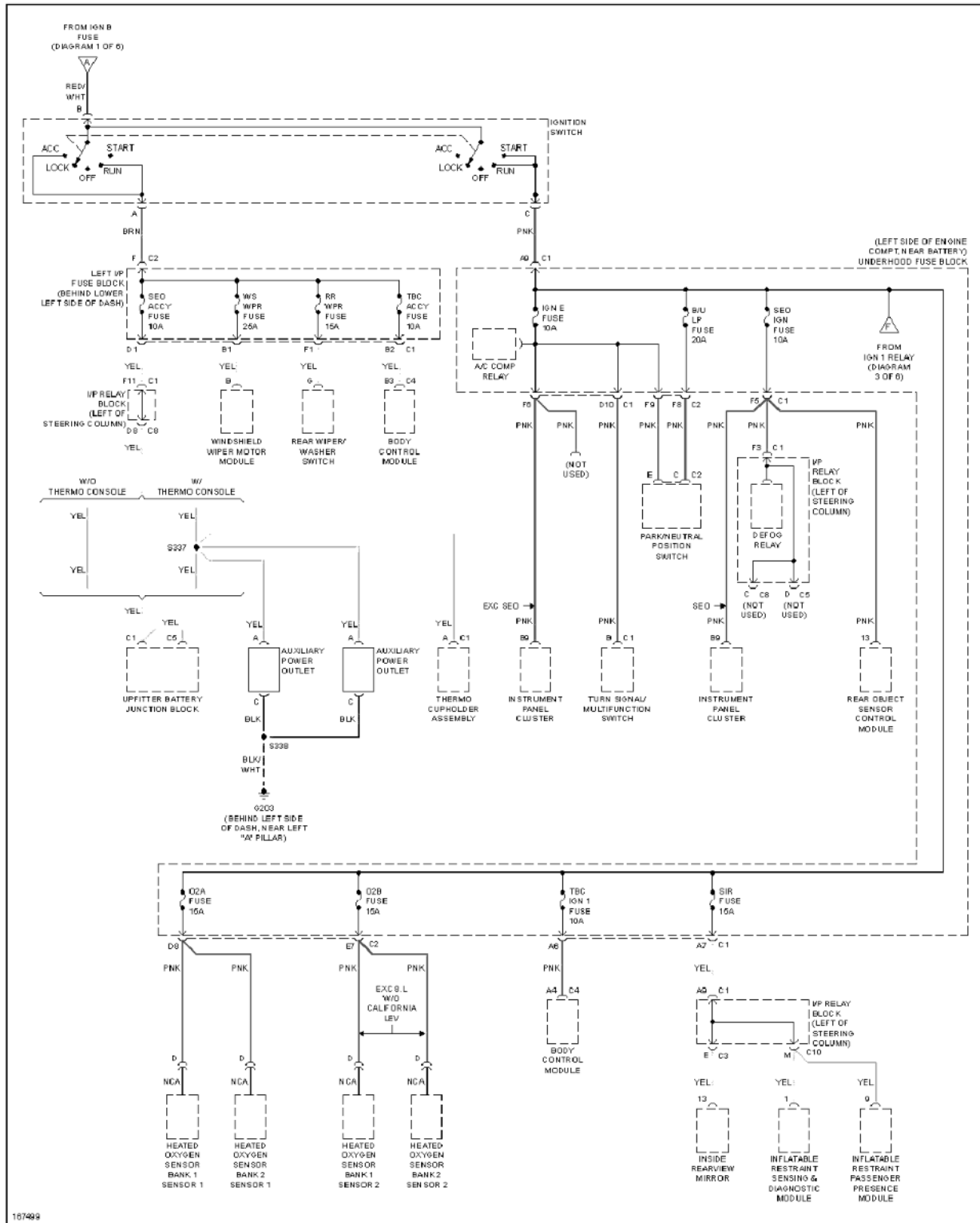
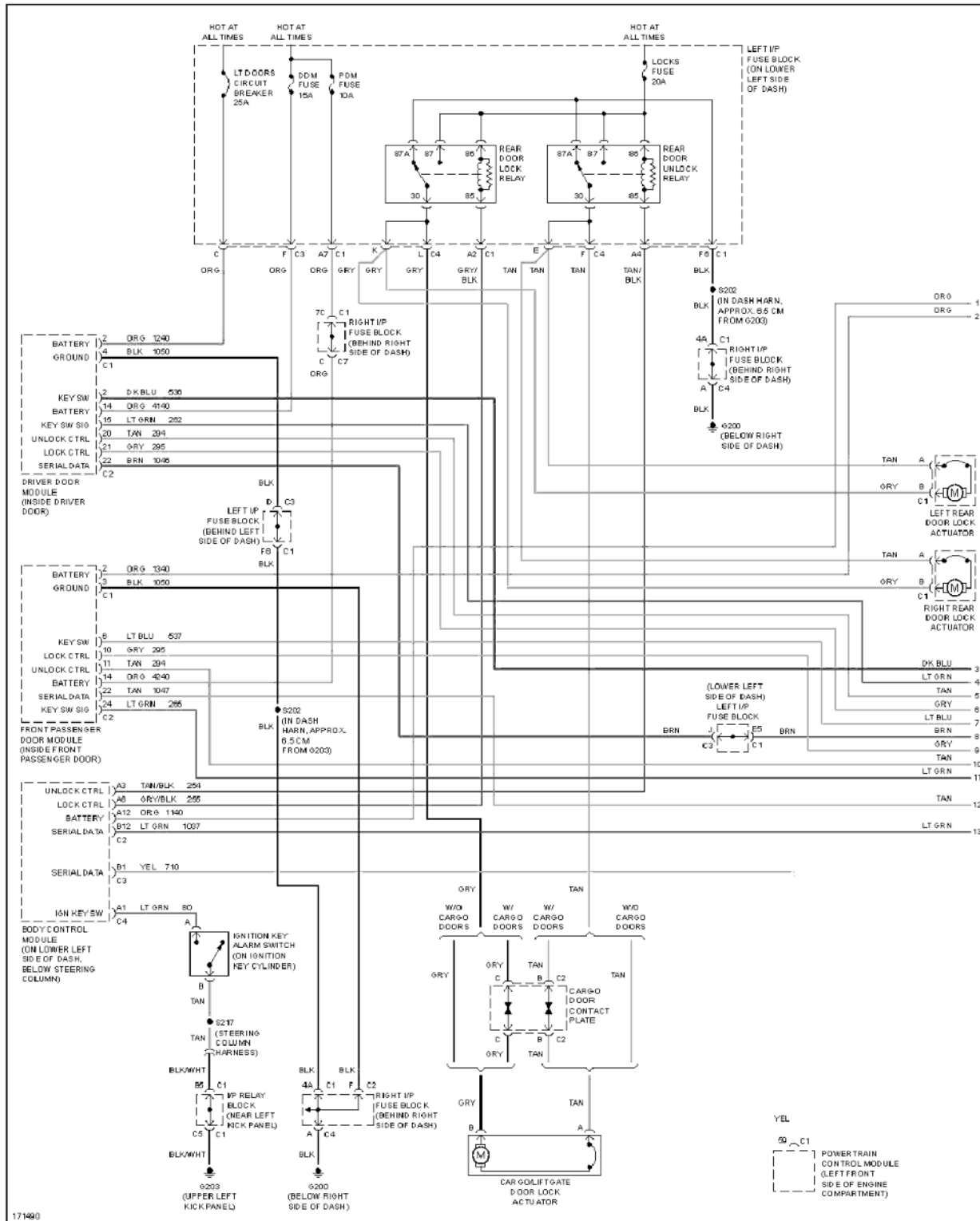

Fig. 71: Power Distribution Circuit (6 of 6)

### POWER DOOR LOCKS

# 2003 Chevrolet Suburban C1500

## 2003 SYSTEM WIRING DIAGRAMS Chevrolet - Suburban



**Fig. 72: Power Door Locks Circuit (1 of 2)**

# 2003 Chevrolet Suburban C1500

2003 SYSTEM WIRING DIAGRAMS Chevrolet - Suburban

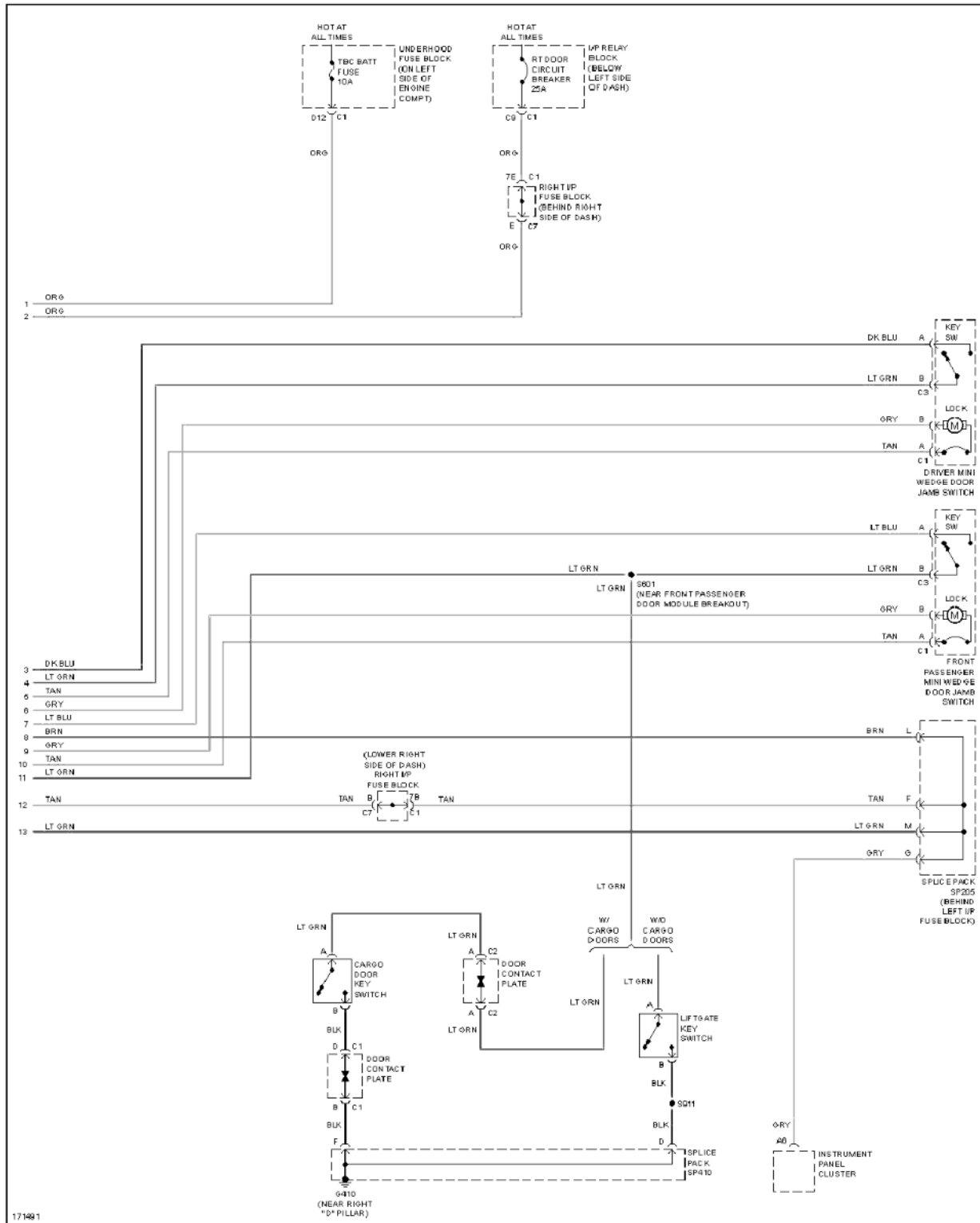
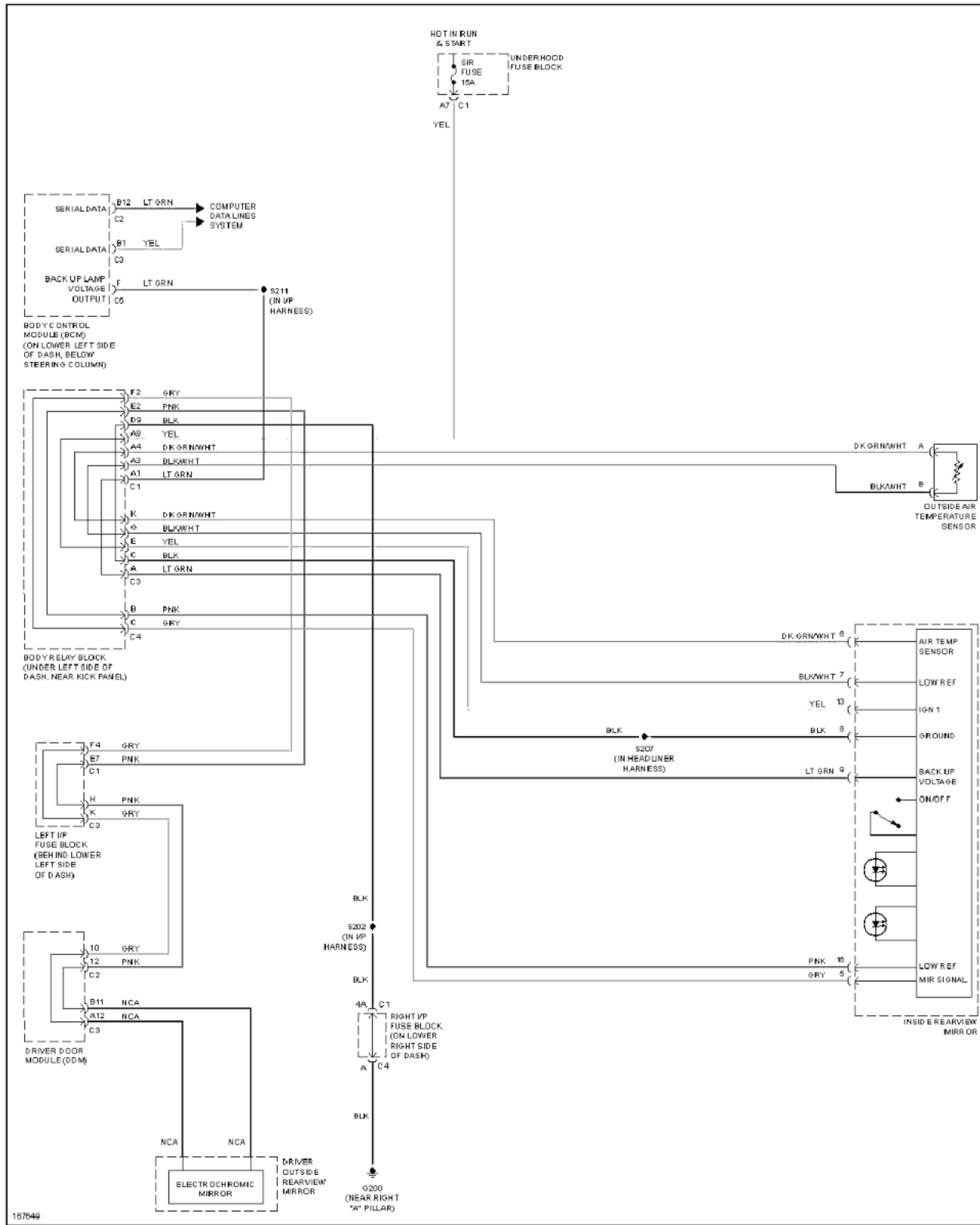

Fig. 73: Power Door Locks Circuit (2 of 2)

## POWER MIRRORS

# 2003 Chevrolet Suburban C1500

## 2003 SYSTEM WIRING DIAGRAMS Chevrolet - Suburban



**Fig. 74: Electrochromic Mirror Circuit**

# 2003 Chevrolet Suburban C1500

## 2003 SYSTEM WIRING DIAGRAMS Chevrolet - Suburban

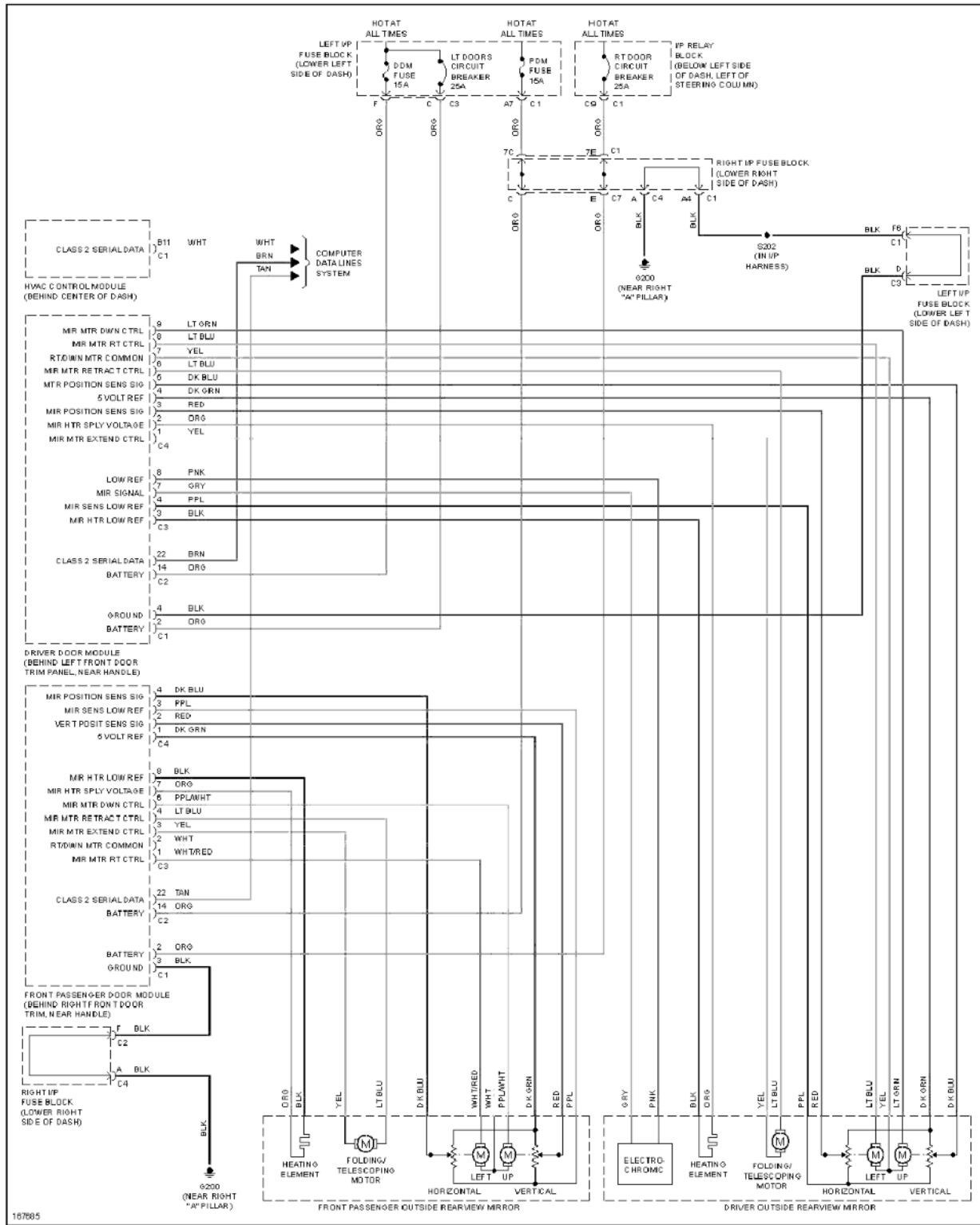
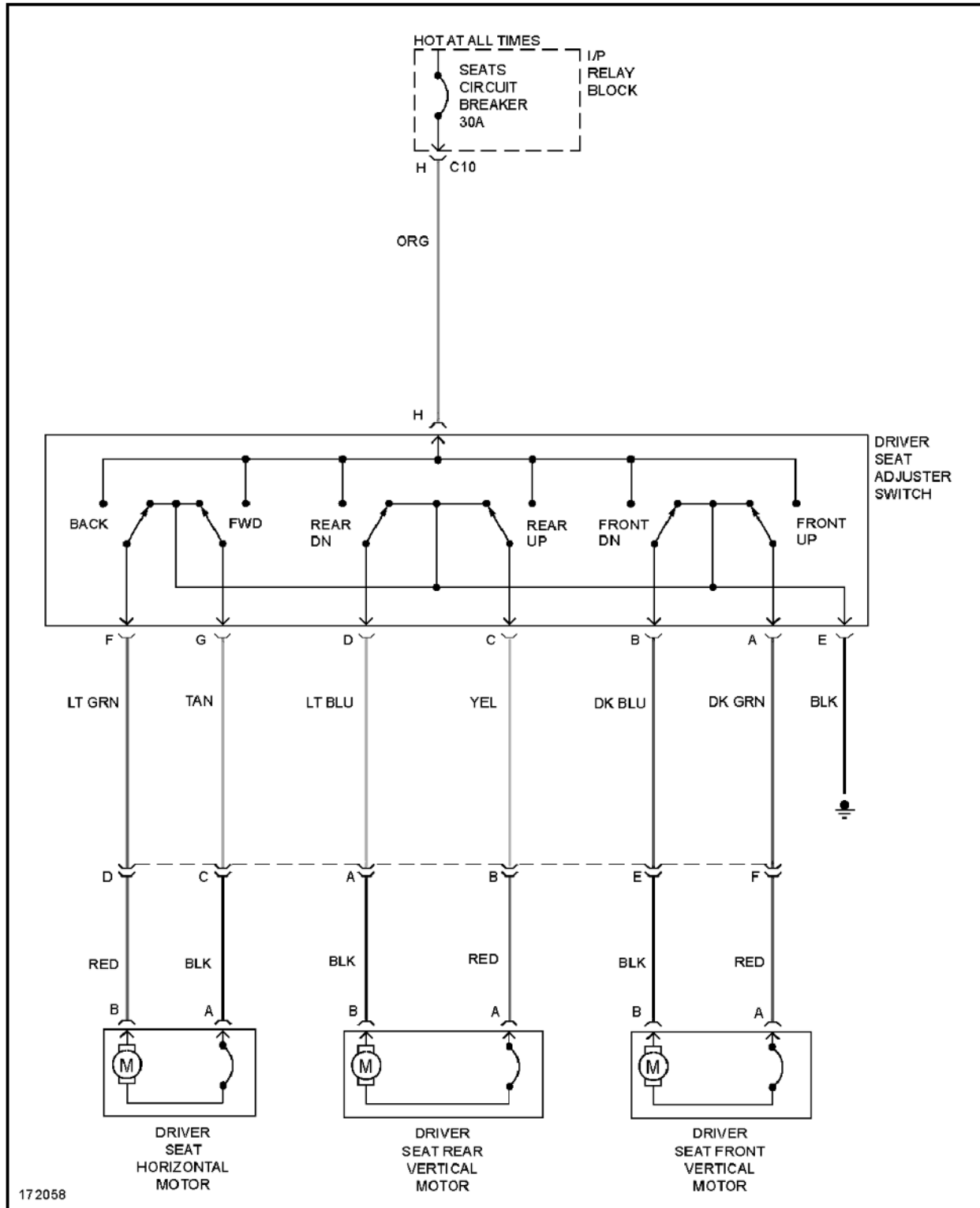

Fig. 75: Power Mirrors Circuit

### POWER SEATS

# 2003 Chevrolet Suburban C1500

2003 SYSTEM WIRING DIAGRAMS Chevrolet - Suburban



**Fig. 76: Driver Seat Circuit**

